

INSTRUCTION MANUAL

TMEX-C901, 1201

TAJIMA
(9611)

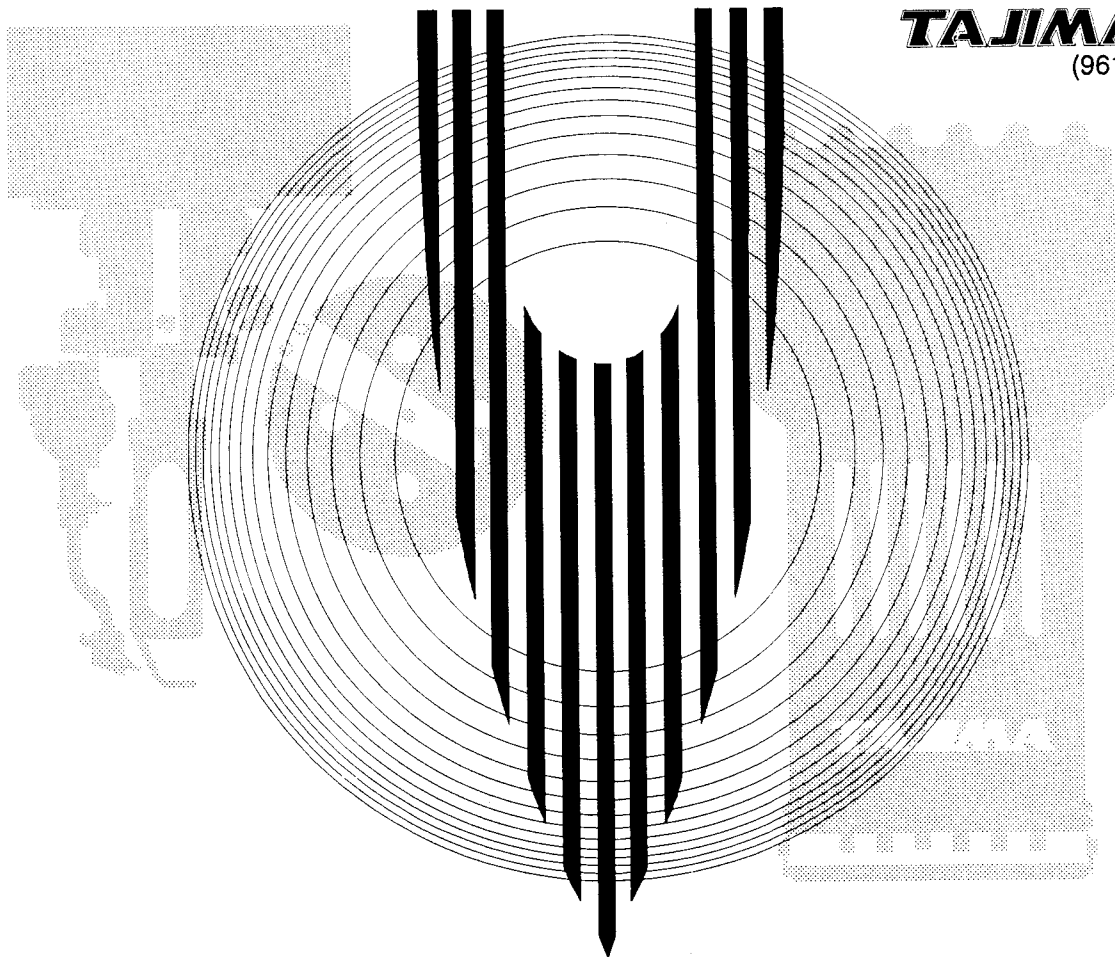

INTRODUCTION

This Instruction Manual contains information useful for operating TAJIMA Automatic Embroidery Machine TMEX-C. Persons who touch a TAJIMA TMEX-C for the first time, as well as those who are experienced in the embroidery machine operation, will find this manual helpful for understanding and reconfirming the machine operation procedures. Please read through this manual and understand the contents when operating the embroidery machine.

The contents of this manual are largely divided into the following sections.

IMPORTANT SAFETY INSTRUCTIONS

IMPORTANT WARNING ITEMS FOR SAFE OPERATION

FEATURES AND FUNCTIONS

SYSTEM INSTALLATION & SETTINGS

SETTINGS FOR USING OPTIONAL DEVICES

CAUSES OF THE MACHINE STOPS AND TROUBLESHOOTING

DAILY MAINTENANCE OF THE MACHINE

TECHNICAL INFORMATION

Always keep this manual at hand. Read also the manuals for optional devices for installing and operating them.

This manual may contain discrepancies in detail information when compared with actual machine due to continued research and improvements. If any question about the machine or contents of this manual arises, please consult your local TAJIMA distributor.

Keep this instruction manual for future use.

IMPORTANT SAFETY INSTRUCTIONS

Operation of this machine requires correct operation and appropriate maintenance to ensure safety.

Please read the IMPORTANT SAFETY INSTRUCTIONS in this manual carefully and do not attempt operation or maintenance of the machine before you thoroughly understand the items written under IMPORTANT SAFETY INSTRUCTIONS.

Items which require your special attention on operation and maintenance of the machine are specified following the warning symbol and signal word. These items must be strictly observed to ensure safety during operation and maintenance.

Signal word definition is given below.

 **DANGER** Indicates that there is a lot of danger of death or serious injuries [NOTE 1] if the instruction is not observed.

 **WARNING** Indicates that there is a likelihood of death or serious injuries if the instruction is not observed.

 **CAUTION** Indicates a potentially hazardous situation which, if not avoided, may result in minor or moderate injury [NOTE 2] or property damage.

NOTE 1: A condition caused by electric shock, injury, fracture of a bone, etc., that leads to sequelae, or an injury that necessitates hospitalization or visits to a hospital over a long period.

NOTE 2: An injury that does not necessitate hospitalization or visit to a hospital over a long period.

The items which supplement the information given in the explanatory texts are described following [REMARK].

CONTENTS

INTRODUCTION

IMPORTANT SAFETY INSTRUCTIONS

IMPORTANT WARNING ITEMS FOR SAFE OPERATION	I
Machine Installation Environment	i
Lifting	ii
Installation	iii
Grounding	iv
Cautions on Machine Operation	v
Safety labels	ix
1. FEATURES AND FUNCTIONS	1 - 1
1-1 Electrical Specifications and Installation Environment	1 - 3
1-2 Names of Parts	1 - 4
1-3 Tension Base Switch and Thread Breakage Indicator Lamp	1 - 5
1-4 Power Supply/Driver Unit	1 - 6
1-5 Key Switches and Indicators on the Operation Panel (Controller Box)	1 - 7
1-6 Start and Stop Switch Operations	1 - 12
1-7 Emergency Stop Switch	1 - 13
2. SYSTEM INSTALLATION & SETTINGS	2 - 1
2-1 Precautions for Handling Floppy Disks	2 - 1
2-2 Inserting and Removing a Floppy Disk	2 - 2
2-3 System Installation	2 - 3
2-4 Display Screen	2 - 7
2-5 Inspections before Starting Operation	2 - 8
2-6 Basics of Operation	2 - 9
2-7 General Description of Setting Items	2 - 10
3. USING MENU KEY A	3 - 1
3-1 Data Input (Memory)	3 - 2
3-2 Data Input (Floppy Disk)	3 - 3
3-3 Data Input (PTR)	3 - 5

3-4	Data Input (Serial)	3-7
3-5	Memory Delete	3-9
3-6	Standby Data Input (Outline of Standby Data Input Function)	3-10
3-7	Standby Data Input	3-13
4.	USING MENU KEY B	4-1
4-1	Automatic Color Change/Automatic Start	4-1
4-1-1	Automatic Color Change	4-1
4-1-2	Automatic Start	4-2
4-2	Needle Bar Selection	4-4
4-2-1	Example (1)	4-4
4-2-2	Example (2)	4-7
4-3	Data Conversion	4-9
4-4	Repeat	4-12
4-5	Manual/Automatic Offset	4-17
4-6	Automatic Offset	4-19
4-7	Automatic Free Setting Offset	4-20
4-7-1	Data Input Setting	4-20
4-7-2	Needle Bar Selection Setting	4-20
4-7-3	Automatic offset setting	4-22
5.	USING MENU KEY C	5-1
5-1	Maximum RPM	5-1
5-2	Total Stitch Counter/Design Timer	5-2
5-3	Frame Back/Forward	5-3
5-4	Frame Back/Forward in Color Change Units	5-4
5-5	Automatic Origin Return	5-5
6.	USING MENU KEY D	6-1
6-1	Manual Color Change	6-1
6-2	Manual ATH	6-2
6-3	Manual Origin Return	6-3
6-4	Manual Offset	6-4
6-5	Manual Frame Traveling	6-5
7.	USING THE F1 KEY	7-1
7-1	Jump Conversion	7-1

7-2	Automatic Jump	7-4
7-3	Satin Stitch Conversion	7-5
7-4	Software Frame Limit	7-6
8.	USING THE F2 AND F3 KEYS	8-1
8-1	Low Speed RPM	8-1
8-2	Number of Start Inching	8-2
8-3	Frame Travel Speed	8-3
8-4	Upper Thread Breakage Detection	8-4
8-5	ATH (Automatic Thread Trimming)	8-5
8-6	Max. RPM Limiter	8-7
8-7	Frame Drive Start Timing	8-8
8-8	ATH Timing	8-9
9.	USING THE DATA EDIT KEY	9-1
9-1	General Description of Data Editing	9-1
9-2	Data Editing (Modify)	9-2
9-3	Data Editing (Insert)	9-7
9-4	Data Editing (Delete)	9-13
10.	USING THE FLOPPY PROCESS KEY	10-1
10-1	Floppy Disk Processing	10-1
10-2	Floppy Disk Processing (Write)	10-2
10-3	Floppy Disk Processing (Delete)	10-5
10-4	Floppy Disk Processing (Initialize)	10-6
11.	CONFIRMATION MODE	11-1
11-1	General Description	11-1
11-2	Example of Confirmation Operation	11-2
12.	USING THE F3 AND F4 KEYS	12-1
12-1	OPTIONAL DEVICES	12-1
12-2	UTC (Under Thread Breakage Detection)	12-2
12-3	BOR (Boring)	12-3
12-4	COD (Cording)	12-4
12-5	Network Connection	12-5
13.	CAUSES OF MACHINE STOPS AND TROUBLESHOOTING	13-1
13-1	Error Messages	13-1

13-2 Troubleshooting	13 - 4
14. DAILY MAINTENANCE OF THE MACHINE	14 - 1
14-1 Daily Maintenance of the Machine	14 - 1
14-2 Cleaning	14 - 1
14-3 Lubrication	14 - 3
14-4 Greasing	14 - 5
14-5 Inspection	14 - 6
14-6 Cautions on Repair	14 - 6

TECHNICAL INFORMATION

Electrical Connection Diagrams	End of Volume
--------------------------------------	---------------

IMPORTANT WARNING ITEMS FOR SAFE OPERATION

IMPORTANT WARNING ITEMS FOR SAFE OPERATION

Machine Installation Environment

 **CAUTION**

The machine installation environment must satisfy the following conditions to prevent malfunctions, failure, and physical damage.

- Install the machine on a sturdy floor.
- Prevent the operation noise in the environment.

The floor structure must be strong enough to bear the machine weight (refer to the model name plate on the machines).

To improve the sound insulation performance of the factory in addition to the operation with reduced noise of this machine, use the interior finish materials which show high sound insulating performance for the walls, ceiling, and floor of the factory.

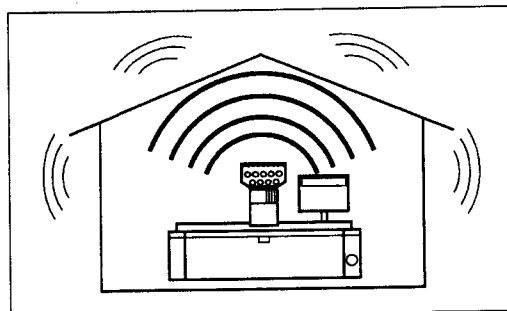
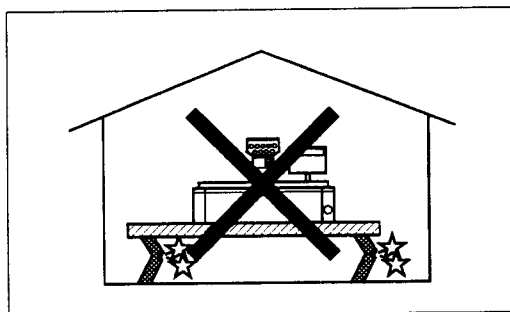

- Avoid direct sunlight.

If the machine is exposed to direct sunlight over an extended period of time, the machine body may cause discoloration or deformation. Put curtains or shades to stop direct sunlight.

- Avoid dust and moisture.

Dust and moisture lead to dirt and rust on the machine. Install air conditioning equipment, and periodically clean the working area.

Use caution not to expose the machine to direct wind from the air conditioner so that the embroidery threads do not become disheveled.

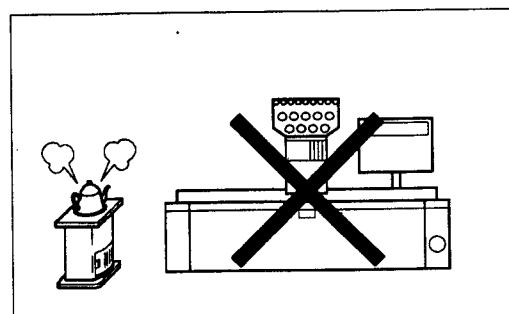
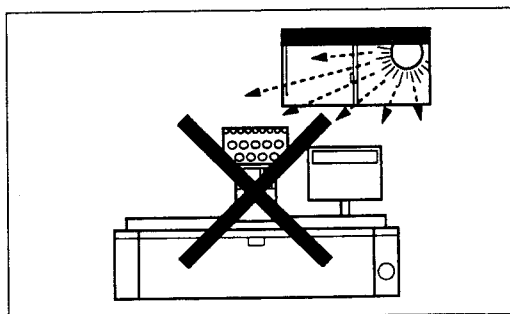

- * Humidity : 30 to 95%RH (relative humidity), without condensation
- * Ambient temperature : 5 to 40°C (41 to 104°F) (during operation),
-10 to 60°C (14 to 140°F) (during storage)

IMPORTANT WARNING ITEMS FOR SAFE OPERATION

Lifting

 **DANGER**

When lifting (suspending) the machine, make sure that there is no person standing in the danger area around the machine, especially under the machine.

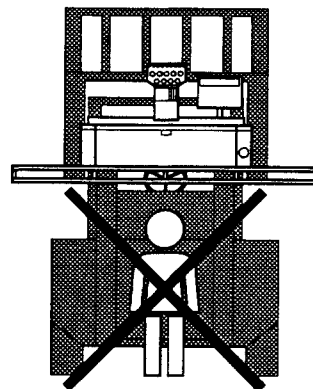

 **WARNING**

The following instructions must be observed when lifting the machine to prevent accidents resulting in injury or death and physical damage.

- When carrying the machine manually, put on safety shoes and hold the machine securely at the handles.
- When a forklift *[NOTE]* is used to lift the machine, lift the machine in the manner shown below. Make sure that the gravity center mark (indicated on the front and rear sides of the machine stand) is placed at the center between forks.

NOTE: Use the forklift which has the sufficient capacity to lift the machine.

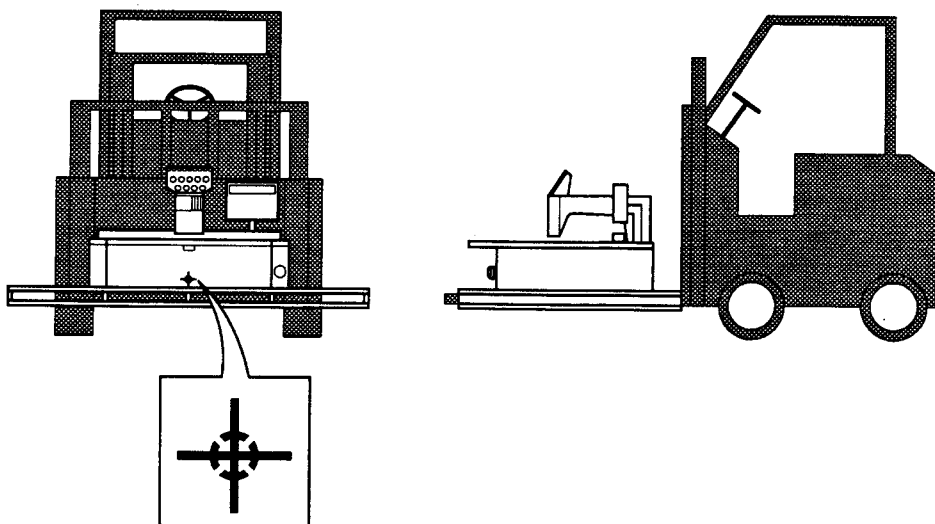

IMPORTANT WARNING ITEMS FOR SAFE OPERATION

Installation

⚠ CAUTION

- If the machine is installed with the machine body twisted, it causes the needle locating position to fluctuate. Therefore, adjust the machine level in the back and forth (lengthwise) and right/left (crosswise) directions during machine installation.
- Place a precision level at the specified positions when adjusting the machine level.

<Procedure>

[When the machine is not equipped with the special stand (optional)]

- (1) Place the vibration preventive rubber (a) under the leveling adjuster (b).
- (2) Adjust the machine level by turning the leveling adjuster (b) while reading the precision level [NOTE]. Finally, fix the leveling adjuster with the nut (c).

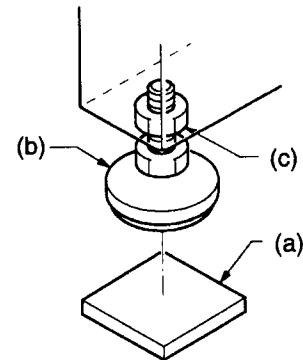

[When the machine is equipped with the special stand (optional)]

- (1) Fit the leveling block (a) in the hole (c) in the machine base (b).
- (2) Place the vibration preventive rubber (d) under the leveling block (a).
- (3) Turn the leveling block (a) to lift the caster (e).
- (4) Adjust the machine level by turning the leveling block (a) while reading the precision level [NOTE]. Finally, fix the leveling block with the nuts (f).

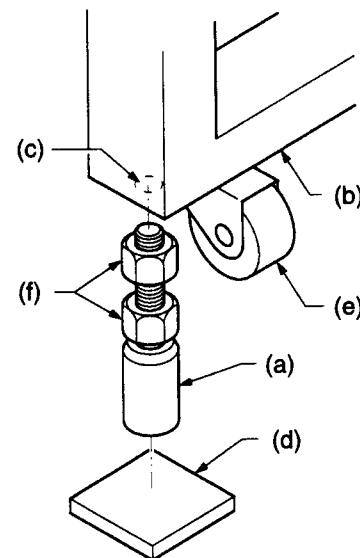

NOTE: Place the precision level (g) at the positions shown in the illustration below.

For adjusting the machine in the lengthwise (back and forth) direction

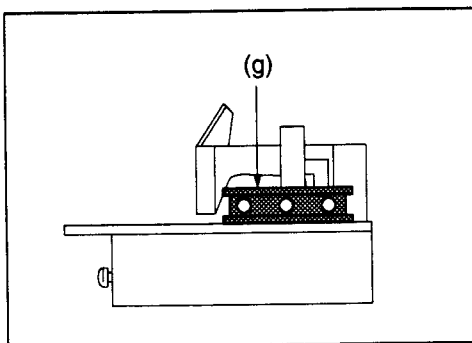

For adjusting the machine level in the crosswise (right and left) direction

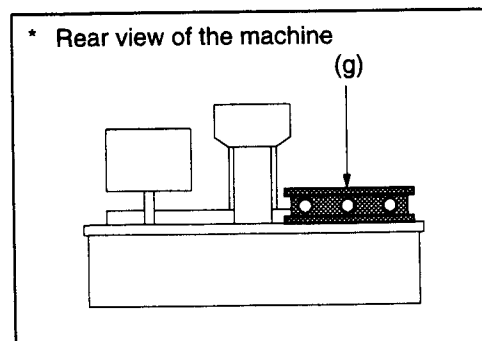

IMPORTANT WARNING ITEMS FOR SAFE OPERATION

Grounding

⚠ WARNING To prevent an electric shock due to leak current, the grounding wire must be properly connected.

Provide class 3 grounding or above (the grounding resistance must be 100 ohms or less).

⚠ CAUTION Before connecting the power cable plug, turn off the power switch.

<Procedure>

Ground the machine by using either of the following methods.

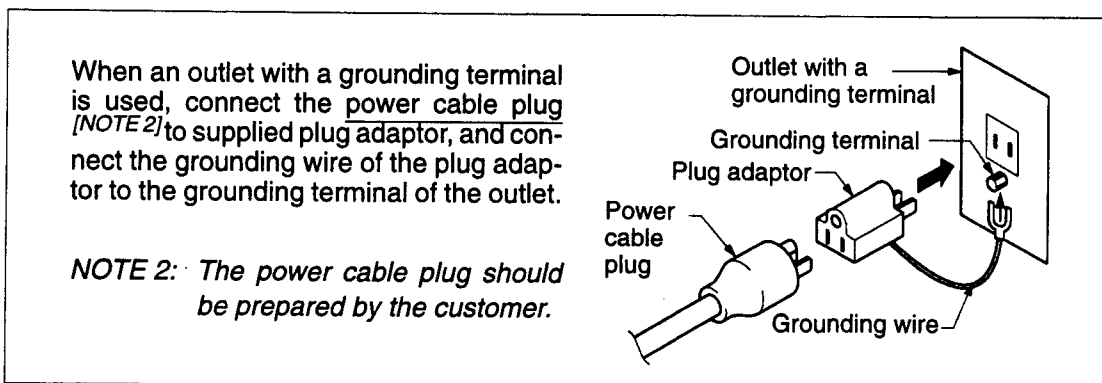
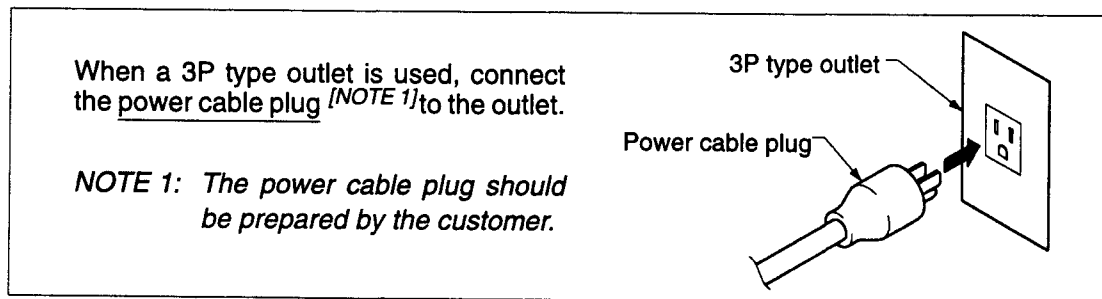

<Leakage breaker>

If a leakage breaker is used, select one provided with a measure against harmonics. [NOTE 3]

NOTE 3: If a leakage breaker without this measure is used, the breaker will frequently trip (power shutdown).

IMPORTANT WARNING ITEMS FOR SAFE OPERATION

Cautions on Machine Operation

WARNING

To prevent accidents resulting in injury or death and physical damage, the following must be observed when operating the machine.

■ Before starting the machine

- **This machine is for industrial use.**
This machine has been designed to perform embroidering on semi- and final textile products and similar materials. Uses other than these must be avoided.
- **Use the machine in the environment where only authorized persons are permitted to enter, so that the machine is not manipulated by unauthorized persons.**
- **The machine must be operated only by the persons who are sufficiently trained for the operation.**
- **The working area of this machine is at the front of the machine. You are allowed to operate the machine only within the specified working area. If it is necessary to operate the machine while you are standing outside the specified working area, you must exercise due care so that you will not sustain injury.**
- **Do not stand on the machine.**
- **Read this manual and thoroughly understand the contents of operation before starting the machine.**

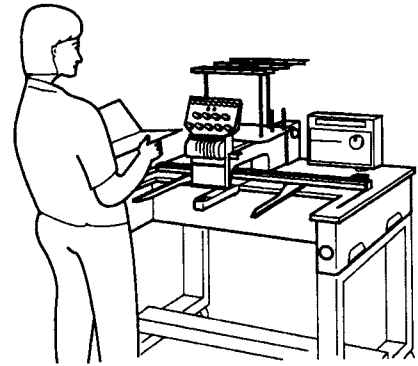

- **Wear proper clothes and tidy up yourself so that you can smoothly perform the operation.**

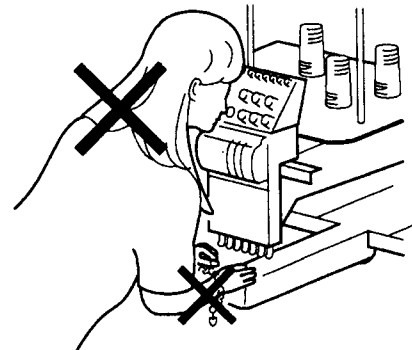

IMPORTANT WARNING ITEMS FOR SAFE OPERATION



WARNING

- Make sure that no one is working near the moving parts of the machine, and then, start the machine.

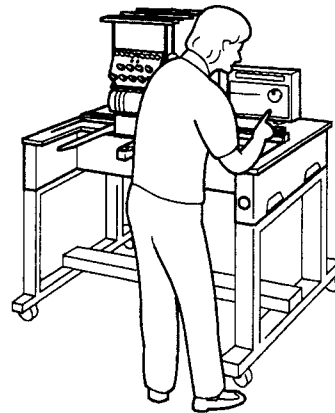

■ During the machine operation



WARNING

- Do not put your hands or face near the moving parts of the machine. Moving needle, take-up lever, and pulleys are very dangerous.

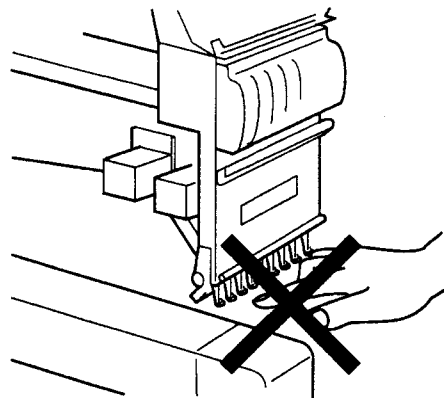

- Do not remove the covers for the shaft and pulleys when the machine is running. Do not run the machine without the cover.

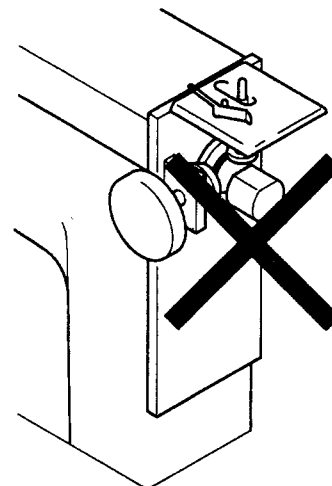

IMPORTANT WARNING ITEMS FOR SAFE OPERATION

■ During machine adjustment

- **Disconnect the power supply to the machine before opening the electrical boxes. Be sure to turn off the power switch of the machine before disconnecting the power to the machine.**
- **Be sure to stop the machine before carrying out work near the needles (threading the needle, checking the finish of embroidery, etc.).**

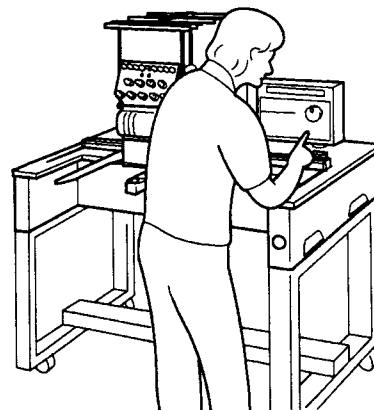

- **Be sure to turn off the power switch before manually turning the main shaft.**

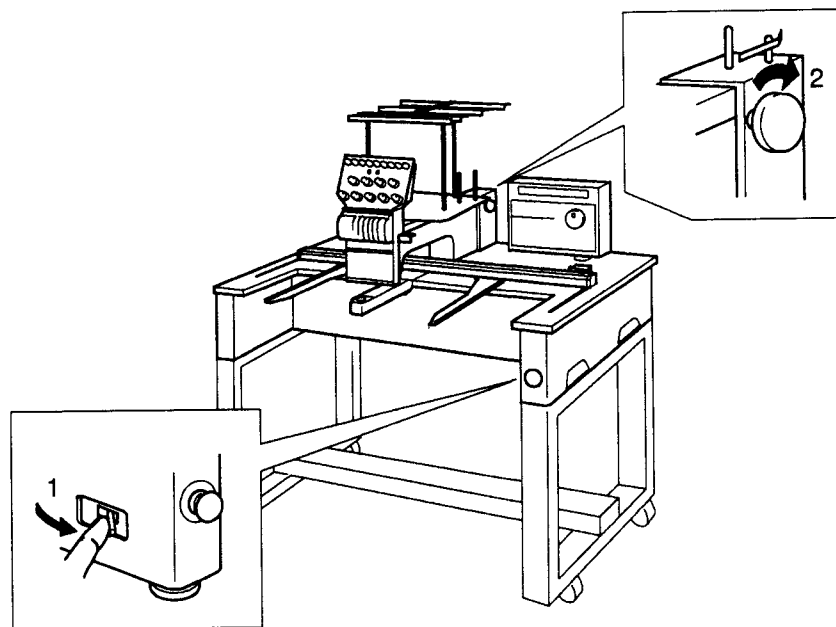

IMPORTANT WARNING ITEMS FOR SAFE OPERATION



CAUTION

When operating the machine, observe the following items to prevent machine damage.

- **Do not put things on the table.**

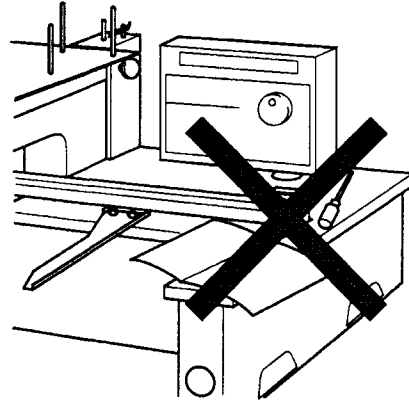

- **Do not use bent or broken needles.**
- **Use the proper needle plate.**

IMPORTANT WARNING ITEMS FOR SAFE OPERATION

Safety labels

IMPORTANT: The machine has safety labels which bear instructions for safe operation. Machine operators must follow these instructions when operating the machine. Do not detach these labels, nor make them illegible by such as painting.

REMARK: If the safety label is missed or damaged, please contact TAJIMA's distributor.

■ Safety Label Position

[Machine Front (Machine left front)]

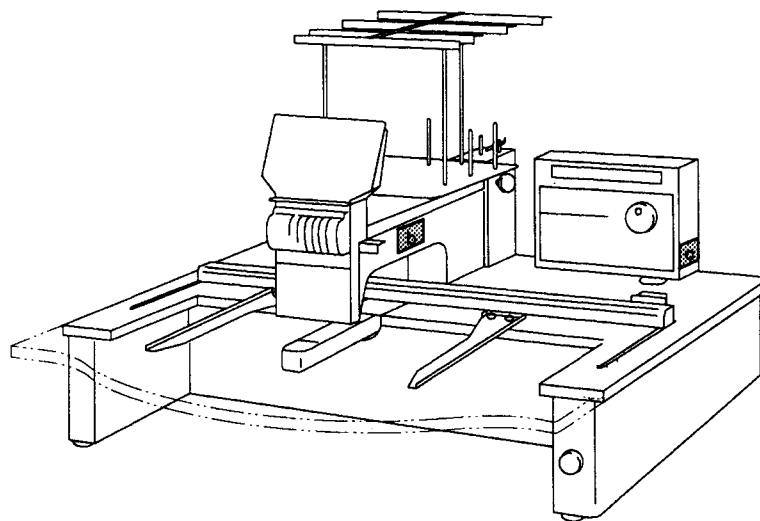

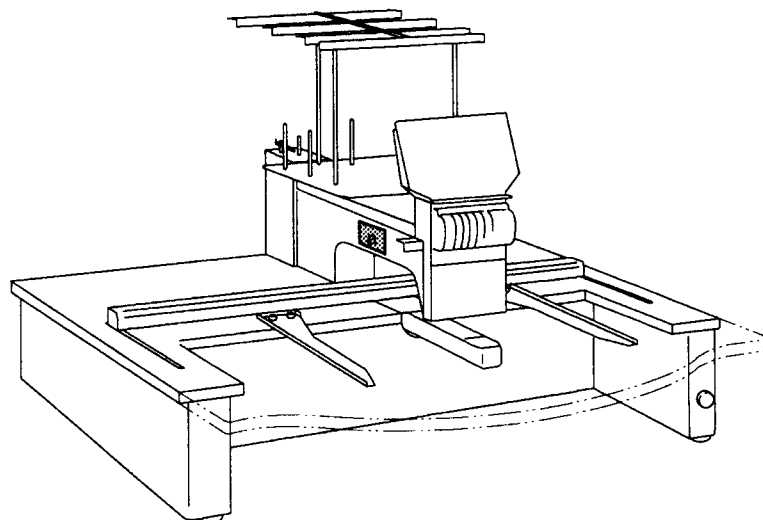

[Machine Front (Machine right front)]



IMPORTANT WARNING ITEMS FOR SAFE OPERATION



■ Contents of Safety Labels

(a)

 WARNING ATENCION		
	<p>Moving parts can cause severe injury.</p> <p>Do not take off the safety covers nor put your hands etc. close to the moving parts during machine operation.</p>	<p>Las partes en movimiento pueden ocasionar lesión grave.</p> <p>No retirar las cubiertas de seguridad ni poner las manos, etc., cerca de las piezas en movimiento mientras la máquina esté en funcionamiento.</p>

304

(b)

 WARNING ATENCION		
	<p>Exposed needles can cause severe injury.</p> <p>Stop the machine before working near the needles.</p>	<p>Las agujas expuestas pueden ocasionar lesión grave.</p> <p>Detenga la máquina antes de trabajar cerca de las agujas.</p>

305

(c)

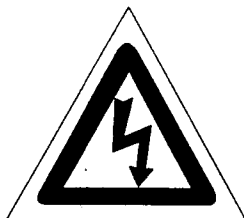

HIGH VOLTAGE

Can cause shock, burn, or death.

- The cover can be opened only by the service persons authorized by Tajima.
- When opening the cover, turn the power switch OFF and wait at least 4 minutes.

1. FEATURES AND FUNCTIONS

1. FEATURES AND FUNCTIONS

- (1) **Accurate frame driving and high-speed capability**
High-precision special pulse motors perform frame driving with improved quietness and stability. The maximum main shaft speed has been increased up to 1200 rpm.
- (2) **Easy-to-install/remove table**
The sub table can be easily installed and removed so standard embroidering and embroidering on finished products can be freely performed.
- (3) **Multiple purposes**
Beautiful embroideries can be produced on both material fabric and finished products such as T-shirts, knitted sweaters, sweat shirts, and caps.
- (4) **Compact body design**
The machine body is compactly designed and portable.
- (5) **Quiet operation**
Noise-reducing mechanisms successfully decrease noise and vibration during operation.
- (6) **Automatic needle bar selector (Patent pending)**
The needle bar order can be selected for maximum efficiency. Up to 99 color changes can be set.
- (7) **Independent take-up lever (Patent pending)**
Only the take-up levers in use move and those not in use do not move. Threads are smoothly supplied at stable tension and upper/under thread trimming is done accurately.
- (8) **Individual tension base**
The tension base moves together with the needle bar case at the time of color change so thread tension is stably maintained.
- (9) **Built-in floppy disk driver (3.5-inch FDD)**
TAJIMA format design data can be read from and written on a floppy disk. Design data of other formats can also be read. Up to 111 designs can be stored in a floppy disk, and the maximum memory capacity is 240,000 stitches.
- (10) **Ternary and binary data (tape format) can be used**
Data type can be automatically selected.
- (11) **Design scale up/down and rotation**
The size of a design can be enlarged or reduced in 1% increments in 50 to 200% range independently in X and Y directions. Rotation can be set in 1° units.

1. FEATURES AND FUNCTIONS

(12) Satin stitch expansion

Stitch width can be expanded in 0.1 to 1.0 mm range wider than the tape data.

(13) Automatic repeat

A design can be repeated up to 99 times respectively in X and/or Y directions.

(14) Large memory capacity (max. 640,000 stitches)

Up to 99 designs can be stored in memory. Available memory size is indicated in the number of stitches. (Standard memory: 128,000 stitches)

(15) Speed changes

Stitching speed can be set using either jog dial. Speed is automatically adjusted according to stitch length.

(16) Automatic/manual offset

The frame moves aside so applique placement, frame changing, etc. can be done easily. The frame can be easily returned to the original position after such operations are completed. Even after the frame has been moved manually during embroidering, the frame can be easily returned to the previous stitch point.

(17) Origin return

The frame can be returned to the start point of the design. Even though the start point does not coincide with the end point, the stitching point can be returned to the start point.

(18) Frame back

The frame can be moved backward in one stitch unit or one color change units if thread skipping, etc. has occurred during embroidering.

(19) Frame forward

The frame can be moved forward in the stitching direction of a design.

(20) Automatic upper/under thread trimming and holding device (ATH)

This device operates as designated in design data. Quality of finish and productivity of designs can be improved. (Manual operation by using a button at desired positions is also possible.)

(21) Direct data input

The design data can be directly input to the machine for data setting from an external connected device such as FM Note and ML-50 without requiring the operation at the operation panel.

1. FEATURES AND FUNCTIONS

1-1 Electrical Specifications and Installation Environment

Please operate your TMEX-C machine according to the electrical specifications and in the environment mentioned below.

 **CAUTION** **Operating or installing the machine in a place where the following electrical specifications and/or environmental requirements are not satisfied may cause operation failure of the machine.**

(1) Electrical Specifications

(a) Allowable voltage range (single-phase only)

± 10% of rated voltage

* The machine has an automatic transformer and can operate under the following input voltages without changing tap configuration of the transformer.
Allowable input voltages: 100, 110, 115, 120, 200, 220, 230, and 240 VAC

(b) Power supply capacity and power consumption

470 VA 330 W

(c) Insulation resistance

10 M Ω or over (by a 500 V megger)

 **CAUTION** **To avoid the danger of electric shock due to leak current, be sure to connect the grounding wire of the machine to the ground.**

Conform to Class 3 grounding (grounding resistance: 100 ohms or less) or higher class.

1. FEATURES AND FUNCTIONS

1-2 Names of Parts

The figure below shows a TMEX with the tubular goods frame specification.

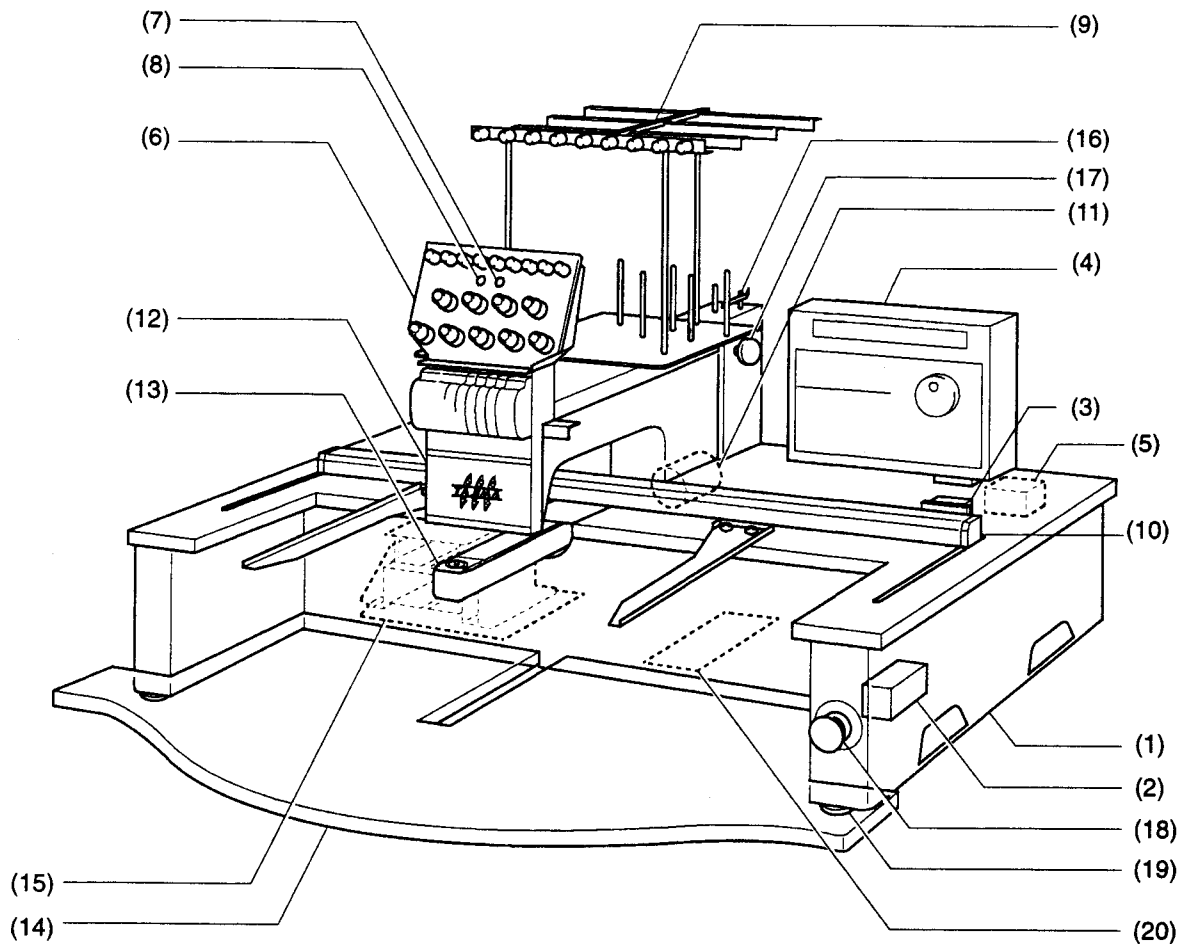

(1)	Support base	(11)	Main shaft motor
(2)	Power supply switch	(12)	Needle bar case
(3)	X-axis pulse motor	(13)	Cylinder bed
(4)	Controller box (Operation panel)	(14)	Table
(5)	Y-axis stepping motor	(15)	Power supply/driver unit
(6)	Individual tension base	(16)	Under-thread winder
(7)	Tension base switch	(17)	Main shaft turning handle
(8)	Thread breakage indicator lamp	(18)	Emergency stop switch
(9)	Thread guide	(19)	Level adjuster
(10)	Z-spec. frame	(20)	Joint card

1. FEATURES AND FUNCTIONS

1-3 Tension Base Switch and Thread Breakage Indicator Lamp

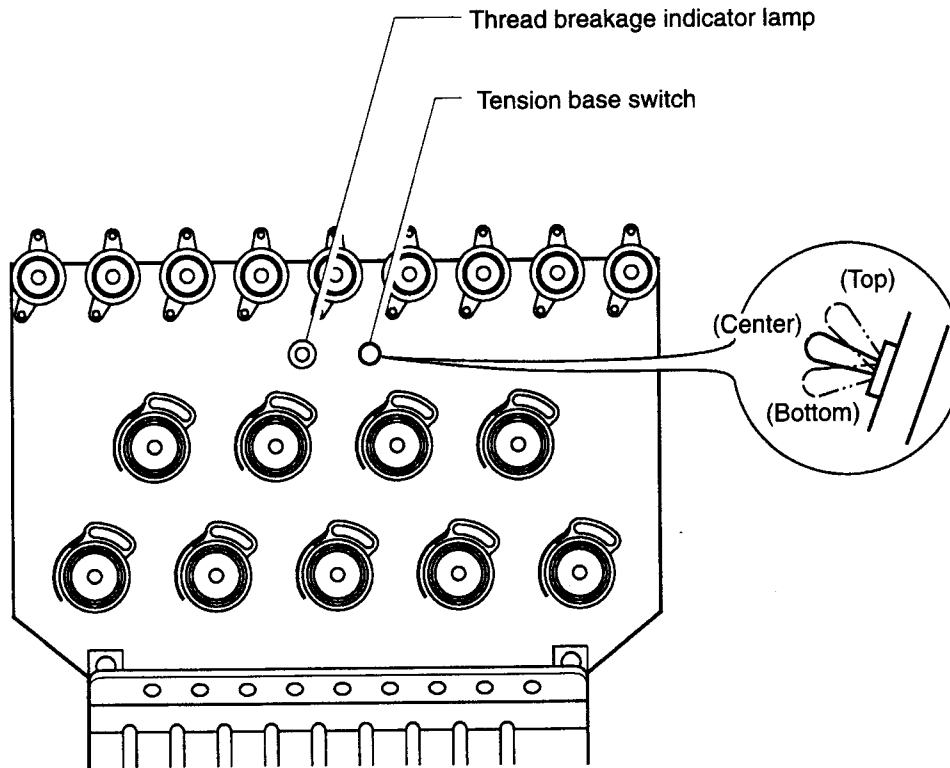

Tension base switch

- (1) This switch must be in the center position during normal operation.

When the machine stopped due to thread breakage, perform frame back to the position of thread breakage and start the machine.

REMARK: To start embroidering beginning with a position after performing frame back, shift this switch to the top position after performing frame back. (The switch returns to the center position by a return spring when it is released.)

- (2) When this switch is shifted to the bottom position, the needle bar in the head does not move. (Embroidering is not performed.)

Thread breakage indicator lamp

- During normal operation : green
- When upper thread breakage is detected : red

1. FEATURES AND FUNCTIONS

1-4 Power Supply/Driver Unit



CAUTION

Do not put an object which will obstruct ventilation under the cooling fan. If the cooling wind flow is blocked, devices in the power supply/driver unit are overheated, causing machine malfunction.

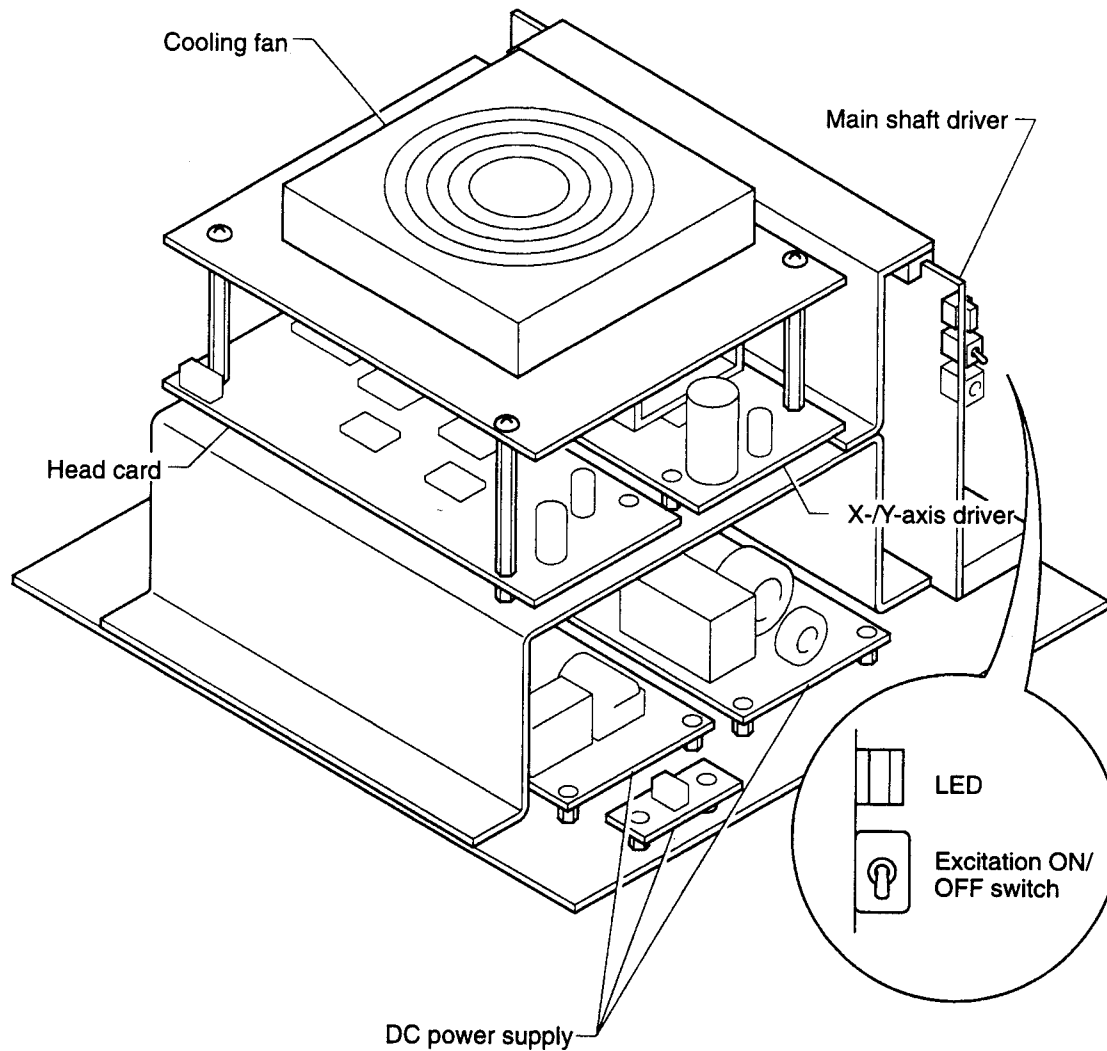

■ LEDs

Indicator LEDs of driver status:

Green : Normal

Orange: Excitation OFF

Red : Abnormal (overcurrent)

■ Excitation ON/OFF switch positions

Top  Excitation OFF

Bottom  Excitation ON

1. FEATURES AND FUNCTIONS

1-5 Key Switches and Indicators on the Operation Panel (Controller Box)

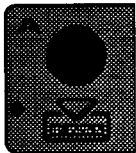
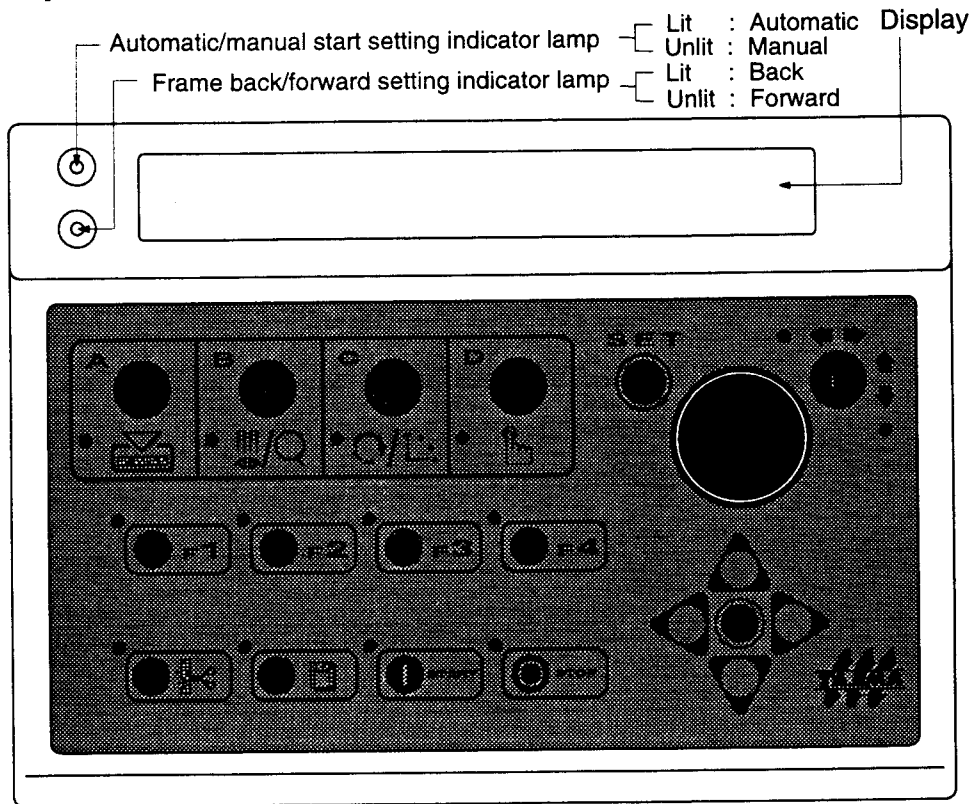

(1) Menu key A

- (a) Data input (Memory) → page 3 – 3
- (b) Data input (Floppy Disk) → page 3 – 5
- (c) Data input (PTR) → page 3 – 7
- (d) Data input (Serial) → page 3 – 7
- (e) Memory delete → page 3 – 9
- (f) Direct data input → page 3 – 10

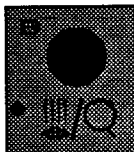

(2) Menu key B

- (a) Automatic color change/automatic start → page 4 – 1
- (b) Needle bar selection → page 4 – 4
- (c) Data conversion → page 4 – 9
- (d) Repeat → page 4 – 12
- (e) Automatic offset → page 4 – 17

1. FEATURES AND FUNCTIONS



- (3) Menu key C
 - (a) Maximum rpm → page 5 – 1
 - (b) Total stitch counter/design timer → page 5 – 2
 - (c) Frame back/forward → page 5 – 4
 - (d) Automatic origin return → page 5 – 5

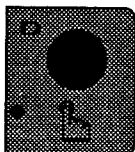

- (4) Menu key D
 - (a) Manual color change → page 6 – 1
 - (b) Manual ATH → page 6 – 2
 - (c) Manual origin return → page 6 – 3
 - (d) Manual offset → page 6 – 4



- (5) SET key
Press this key after inputting each setting item or when selecting a setting item.

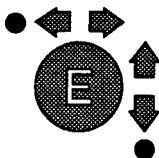

- (6) Manual frame travel key
Press this key to switch to the manual frame travel mode and use either jog dial or the manual frame travel keys *[NOTE 1]*. To exit the manual frame travel mode, press any operation key.

NOTE 1: "Manual frame travel" allows the operator to manually move the embroidery frame by using the switches on the operation panel.

REMARK: By pressing this key while in the parameter setting mode, the input value can be reset to the previous set value and the display mode can be returned to the "normal display" (see page 2 – 7).

1. FEATURES AND FUNCTIONS

(7) Jog dial

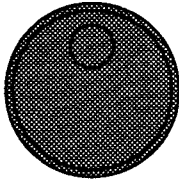

(a) The jog dial has the following two functions.

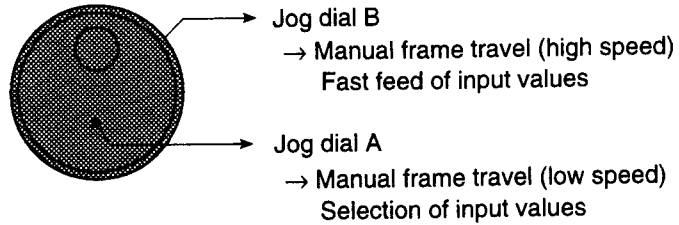

* For example, when an input value for a setting item is 0, 1, 2, 3, 4, or 5, the value indication changes as shown below.

- When turned clockwise

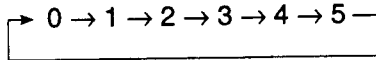

- When turned counter-clockwise

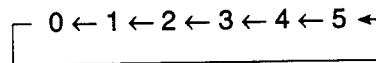

Indication changes in this order.

(b) Manually moves the embroidery frame. See "Moving the frame by using the jog dial" on page 6 – 6.

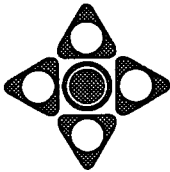

(8) Manual frame travel key

Use this key to manually move the embroidery frame. See "Moving the frame by using the manual frame travel key" on page 6 – 5.



(9) F1 key

- (a) Jump conversion → page 7 – 1
- (b) Automatic jump → page 7 – 4
- (c) Satin stitch conversion → page 7 – 5
- (d) Soft frame limit → page 7 – 6



(10) F2 key

- (a) Low speed rpm → page 8 – 1
- (b) Number of start inching → page 8 – 2
- (c) Frame travel speed → page 8 – 3
- (d) Upper thread breakage detection → page 8 – 4

1. FEATURES AND FUNCTIONS



(11) F3 key

- (a) ATH → page 8 – 5
- (b) UTC → page 12 – 2
- (c) Boring → page 12 – 3
- (d) Cording → page 12 – 4



(12) F4 key

- (a) Network connection → page 12 – 5



(13) Data edit key

- (a) Data editing (modify) → page 9 – 2
- (b) Data editing (insert) → page 9 – 7
- (c) Data editing (delete) → page 9 – 13



(14) Floppy disk process key

- (a) Floppy disk processing (write) → page 10 – 2
- (b) Floppy disk processing (delete) → page 10 – 5
- (c) Floppy disk processing (initialize) → page 10 – 6



(15) Start switch

- (a) Start and Stop Switch Operations → page 1 – 12



(16) Stop switch

- (a) Start and Stop Switch Operations → page 1 – 12

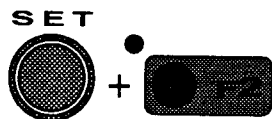

(17) SET key + F2

- (a) Maximum rpm limiter → page 8 – 7
- (b) Frame drive start timing → page 8 – 8
- (c) ATH timing → page 8 – 9

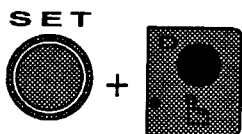

(18) SET key + menu key D

- (a) Confirmation mode → page 11 – 1

1. FEATURES AND FUNCTIONS

[Right side view]

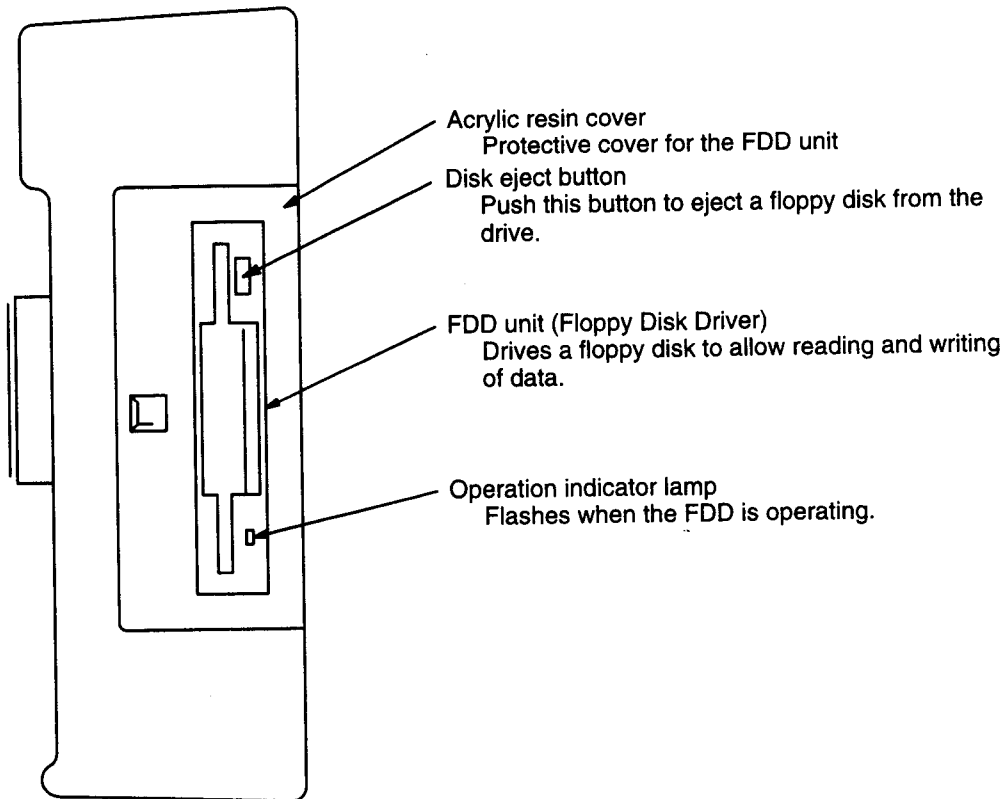

[Bottom side view]

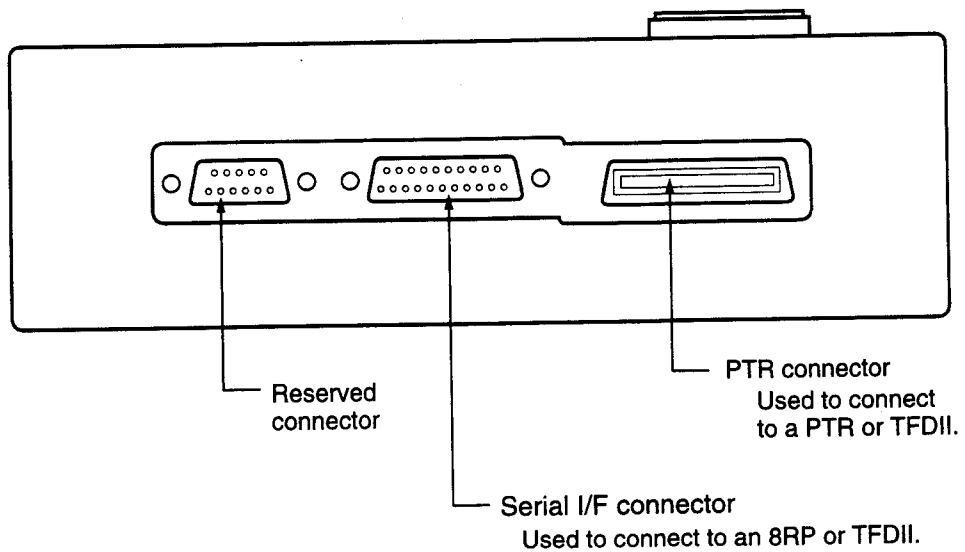

1. FEATURES AND FUNCTIONS





1-6 Start and Stop Switch Operations



Start switch



Stop switch

Machine State Switch Operation	Stopping	Operating
 Press and release the start switch	Operation start	
 Keep on pressing the start switch	Operation start (inching continues)	
 Press and release the stop switch	Frame moves one stitch backward or forward.	Machine stops.
 Keep on pressing the stop switch ↓ Pressing again after frame back/forward of more than 10 stitches →	Frame back or frame forward - When released within 10 stitches, frame travel is terminated. * Within the frame back or forward interval, the frame continues traveling at a low speed. - When released after making frame back/forward more than 10 stitches, the frame continues traveling. It is possible to adjust the frame travel speed by turning the jog dial (in the range equivalent to 250 to 1200 rpm). → Frame back/forward is terminated.	

NOTE 1: The speed is displayed after converted into main shaft rotating speed (rpm). Actual speeds will vary according to stitch lengths.

NOTE 2: The initially set value is 1000 (rpm). If frame back/forward is executed again after stopping it once, the speed setting returns to the initial value.

1. FEATURES AND FUNCTIONS

1-7 Emergency Stop Switch

Use this switch to stop the machine in an emergency.

When this switch is pressed, the machine stops and at the same time code No. "2CE" (see page 13 – 2) is displayed at the display unit on the operation panel.

To restart the machine, press the  key switch to change the display to the "normal display" (see page 2 – 7) *[NOTE 1]* and then press the start switch. *[NOTE 2]*

NOTE 1: If the emergency stop switch has been pressed during frame stepping by jump, thread trimming, or frame travel in the intervals between the repeated designs, the display does not return to "normal display" even if the start switch is pressed. Instead, pressing the start switch after the pressing of the emergency stop switch under the state as indicated above causes the machine to restart the operation from the position where it has been stopped due to the pressing of the emergency stop switch. Therefore, make sure that operation restart does not constitute hazards before pressing the start switch.

NOTE 2: Before pressing the start switch, make sure the safety around the machine.

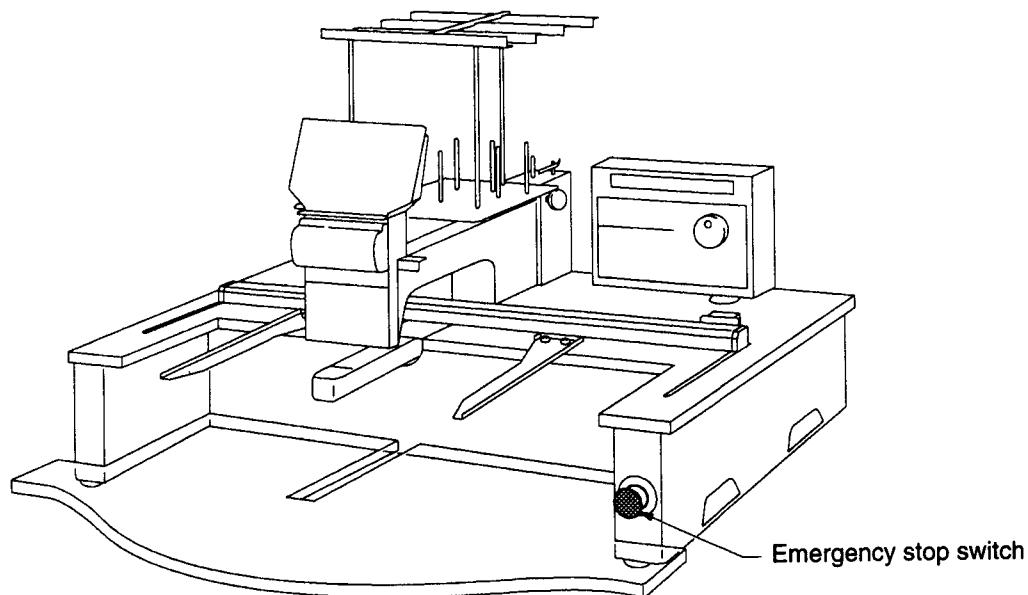

2. SYSTEM INSTALLATION & SETTING

2. SYSTEM INSTALLATION & SETTINGS

2-1 Precautions for Handling Floppy Disks

When handling floppy disks, strictly observe the following items.

NOTE: Although commercially available floppy disks can be used after formatting (see page 10 – 6), TAJIMA does not guarantee the data written to such disks.

- (1) Do not put the floppy disk near magnets or objects such as a TV set which generate a magnetic field.
- (2) Do not expose the floppy disk to excessive heat, humidity, or direct sunlight.
- (3) Do not place heavy objects on the floppy disk.
- (4) Do not try to remove the floppy disk from the floppy disk drive while it is formatted (see page 10 – 1) or while it is accessed (during reading/writing).
- (5) Do not open the shutter.
- (6) When writing the data to the floppy disk, slide the tab of the write protect switch to close the opening.
- (7) Floppy disks do not last eternally. Data must be copied to backup floppy disks for storage.

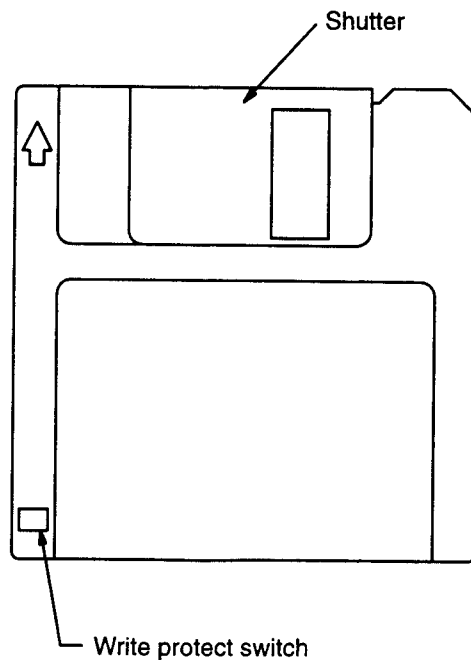

2. SYSTEM INSTALLATION & SETTING

2-2 Inserting and Removing a Floppy Disk

(1) Insertion

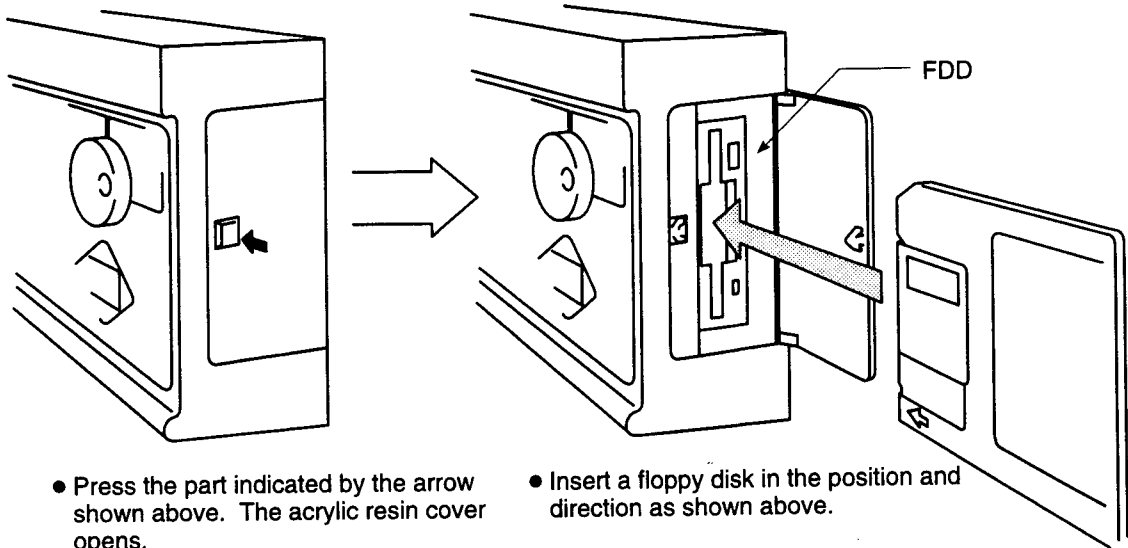

(2) Removal



CAUTION

Do not try to remove the floppy disk from the floppy disk drive while it is formatted (see page 10 - 1) or while it is accessed (during reading/writing).

If the floppy disk is removed in such cases, the data in the floppy disk could be destroyed.

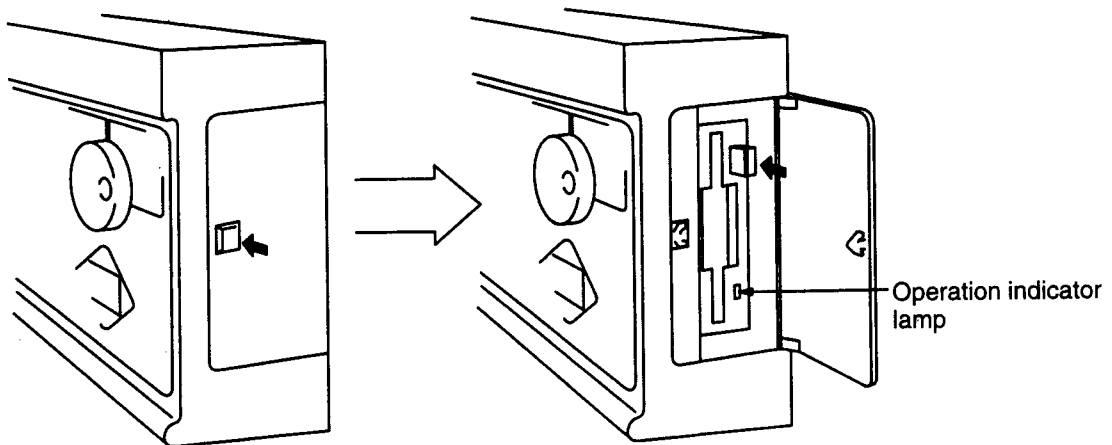

2. SYSTEM INSTALLATION & SETTING

2-3 System Installation

The system installation procedure is required when setting (installing) a program (system) to the computer on the machine. This is done when first setting up the system or when upgrading the system to a newer version.



CAUTION

The system installation operation erases whole embroidery data stored in memory. Do not forget to store necessary embroidery data in floppy disks *[NOTE 1]* before performing the system installation.

NOTE 1: See "Floppy Disk Processing (Write)" on page 10 - 2.

<Procedure>

- (1) Turn the power supply switch OFF.

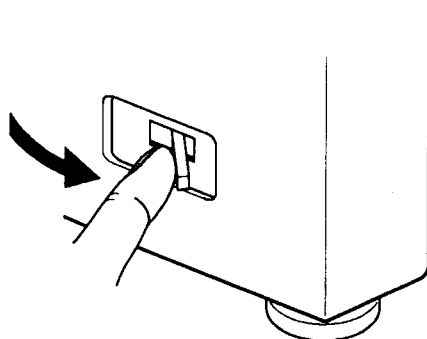

- (2) Insert a system (floppy) disk in the FDD unit.

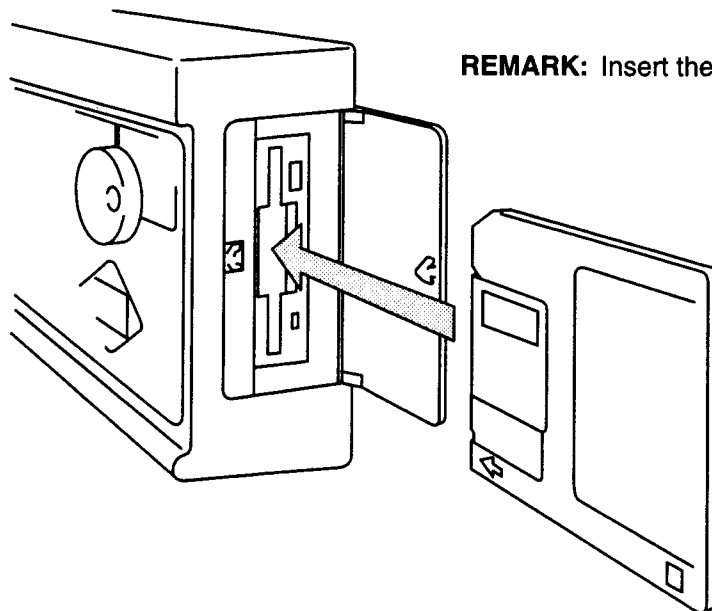

REMARK: Insert the floppy disk correctly.

2. SYSTEM INSTALLATION & SETTING

- (3) Turn the power supply switch ON while pressing the SET key.

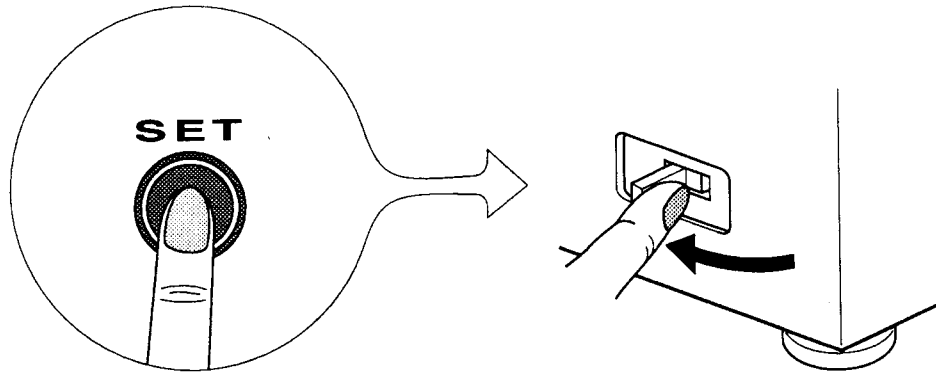

Keep on pressing the SET key after turning the power supply switch ON.

The following message is displayed:



- (4) When the LED of Menu key A comes ON, release the SET key, and press the F3 key until the system installation is completed.

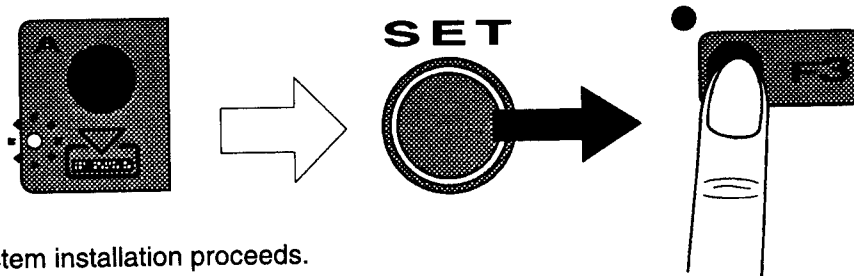

System installation proceeds.

The LEDs of Menu keys A to D come ON in order as system installation proceeds.

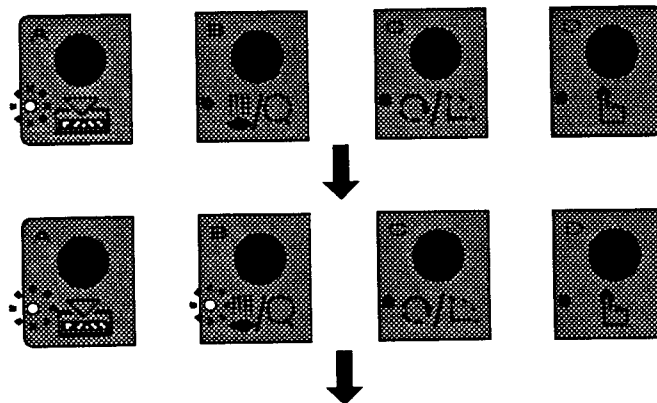

2. SYSTEM INSTALLATION & SETTING

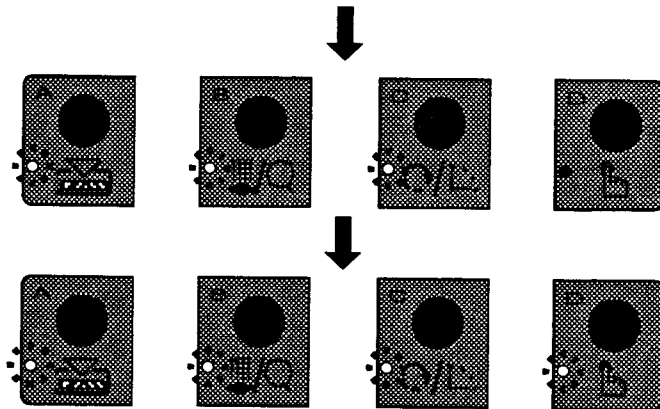

When all the LEDs of Menu keys A to D are lit, system installation is completed. The following message is displayed:

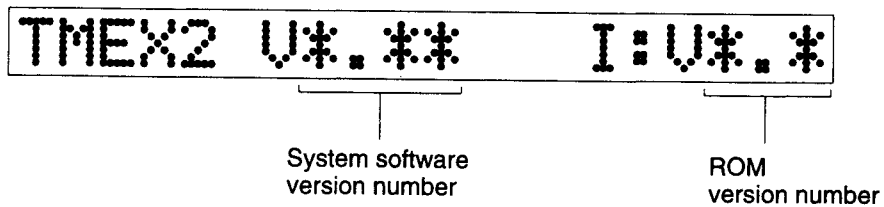

- (5) When the above message is displayed, release the F3 key.

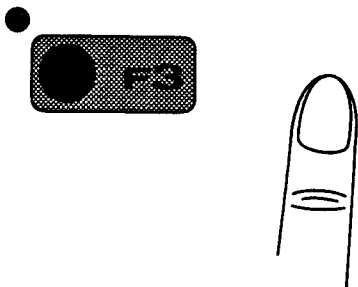

2. SYSTEM INSTALLATION & SETTING

- (6) Shortly after the above message is displayed, the display switches to the number of needles input mode. Set the number of needles of the machine as follows.

Setting the number of needles

N_nos : 6

- a) Select the number of needles by turning the jog dial A.

N_nos : 9

* The number of needles "9" is selected as an example here.

- b) Press the SET key. The display returns to the following "normal display" mode (see page 2 - 7 of the manual).

SET

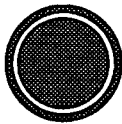

#5 800 M -

- (7) Remove the system (floppy) disk.

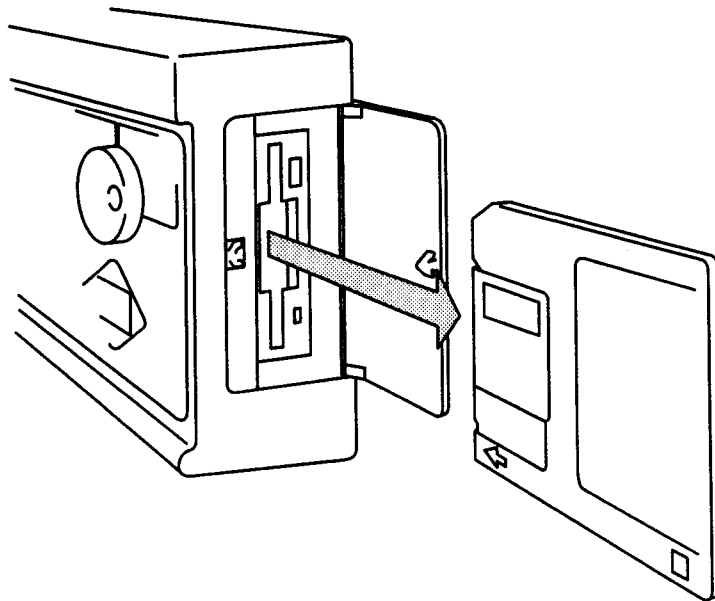

REMARK: When the system is installed, all parameter set values return to Default Settings. Set parameters again if necessary.

2. SYSTEM INSTALLATION & SETTING

2-4 Display Screen

- (1) When the power supply is turned on

When the power supply switch is turned ON, the system executes a self-check and the following message is displayed:

The LCD display shows the text 'TMEX2 V0.00 I:V0.0' in a segmented font. The 'V0.00' and 'I:V0.0' are grouped by brackets below them.

System software version number ROM version number

Version numbers of installed software are displayed.

When the self-check is completed normally, the following display is given.

- (2) Normal display

The LCD display shows '■ # 3 1200 M?'. Brackets are placed under the '3', '1200', and 'M?'.

Fixed position
Displayed when the machine
is stopped in the fixed position
[NOTE 2]

Needle position
Currently selected needle
bar number is displayed.

RPM

Currently set maximum rpm is displayed.

* During frame back/forward, operating speed is displayed after converted into the main shaft speed.

Indicates that data input is not completed.
[NOTE 1]

NOTE 1:

- When data input is completed, design number "M00" is displayed.
- When no design data is registered, "M -" is displayed.

NOTE 2:

The fixed position of the machine is $100^\circ \pm 2.5^\circ$ (main shaft angle of the machine).

- (3) Display during operation

The LCD display shows '# 3 980 37286'. Brackets are placed under '980' and '37286'.

NOTE 3:

The LCD display shows '(1100)' in a segmented font, enclosed in large parentheses.

Actual rpm is displayed.

Stitch counter (per design)

When jog dial A is turned during operation, the maximum rpm setting changes and actual rpm also changes. While the jog dial is turned, the maximum rpm is displayed in brackets [NOTE 3]. When turning of the jog dial is stopped, the brackets disappear and actual rpm is displayed.

2. SYSTEM INSTALLATION & SETTING

2-5 Inspections before Starting Operation

Before starting embroidering, be sure to inspect the following items. If an abnormality is found in the inspections, take the specified corrective measures.

REMARK: If the measures to be taken are not clear, please contact TAJIMA's distributor.



WARNING

Turn off the power switch before carrying out pre-operation inspections.

If the inspections are carried out with the power on, there is a danger that you sustain severe injuries by becoming entangled with the machine or being stabbed by needles.

[Inspections and Corrective Measures]

Inspection	Corrective Measures
Installation of covers	Install all covers to the machine at correct positions.
Setting of embroidery thread	Set embroidery thread correctly. * For the setting procedure, refer to "BASICS -TAJIMA EMBROIDERY MACHINES".
Break and bent of needle	Change the needles. * For the procedure for changing the needles, refer to "BASICS -TAJIMA EMBROIDERY MACHINES".
Lubricated conditions of rotary hook rail, etc.	Supply lubricating oil if necessary. * For the lubrication information, refer to Lubrication (page 14 - 3)

2. SYSTEM INSTALLATION & SETTING

2-6 Basics of Operation

(1) Basic operation flow

The following flowchart shows basic operations to be done before starting embroidery.

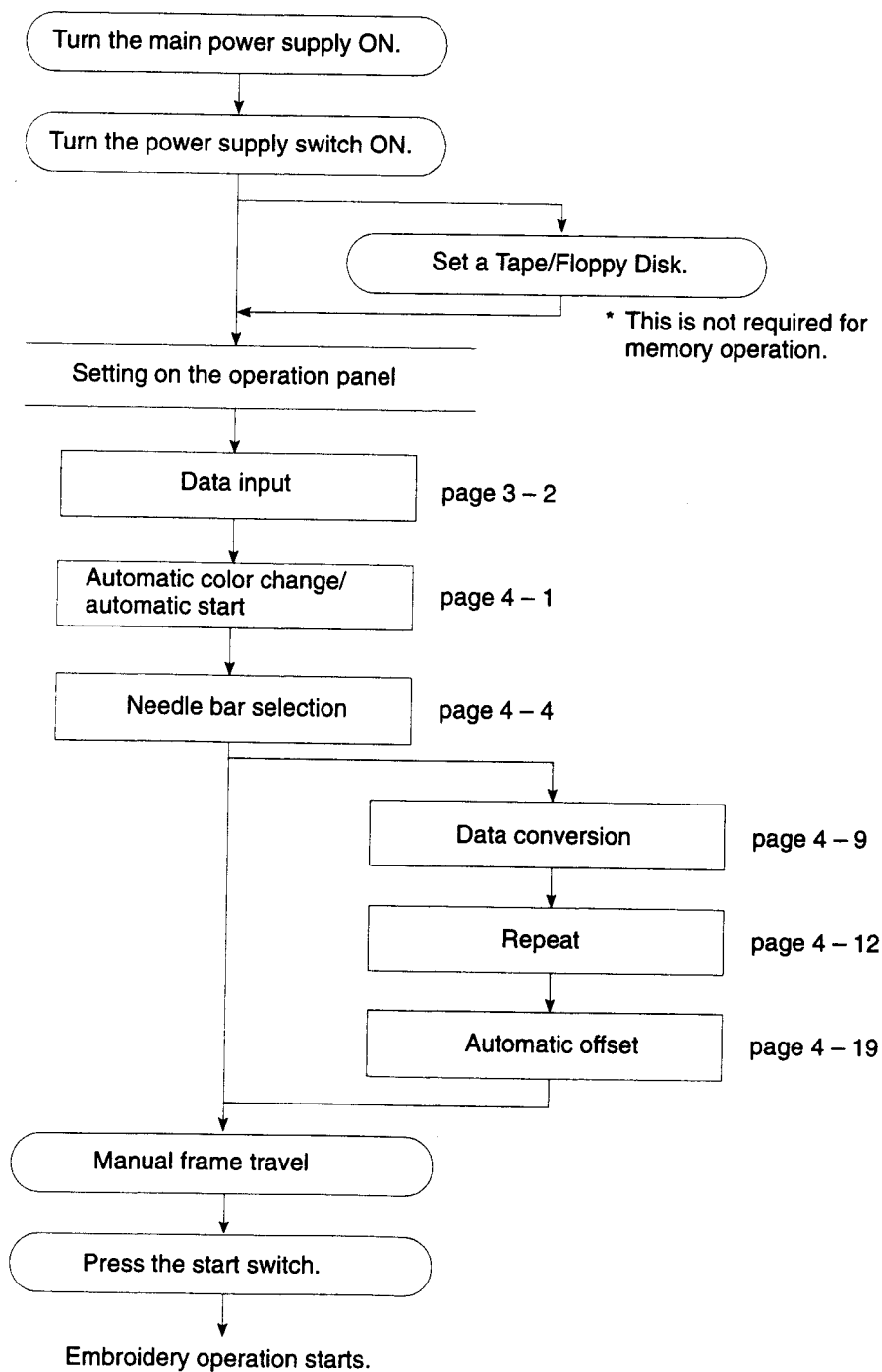

2. SYSTEM INSTALLATION & SETTING

2-7 General Description of Setting Items

■ : Setting that can be made when the embroidery machine is in the embroidery state
(NOTE 1)

□ : Setting that can be made when the embroidery machine is not running

■	Data input	Selects a device to input embroidery data: memory, tape, built-in FDD, and external FDD.	page 3 - 2
□	Memory deletion	Deletes embroidery data stored in memory.	page 3 - 9
□	Direct data input	Input and data set of the design data using an externally connected device (FM Note, ML-50, etc.)	page 3 - 10
■	Automatic color change/ automatic start	Sets whether or not automatic color change and automatic start are executed.	page 4 - 1
■	Needle bar selection	Sets the order of needle bars for automatic color change.	page 4 - 4
□	Data conversion	Sets the reduction, enlargement, rotation, and mirror image conversion of a design.	page 4 - 9
□	Repetition	Sets a design to be repeatedly embroidered.	page 4 - 12
□	Automatic offset	Sets the frame to be moved toward the operator when embroidering is completed.	page 4 - 17
■	Maximum rpm	Sets the maximum rpm of the main shaft.	page 5 - 1
■	Total stitch counter/ design timer	Displays the total number of stitches and the embroidering time of a design.	page 5 - 2
■	Frame back/forward	Selects the frame back/forward operations, and sets the execution of frame back/forward operation in color change units.	page 5 - 4
■	Automatic origin return	Sets the frame to be returned automatically to the design origin point when embroidering is completed.	page 5 - 6
■	Manual color change	Selects the needle bar for manual color change.	page 6 - 1
■	Manual ATH	Manual thread trimming.	page 6 - 2
■	Manual origin return	Manual return to the origin of a design.	page 6 - 3
■	Manual offset	Manual frame travel to the offset position.	page 6 - 4
■	Manual frame travelling	Manual frame traveling.	page 6 - 5
■	Maximum rpm limiter	Sets the maximum rpm of the main shaft.	page 8 - 7
■	Frame drive start timing	Sets the frame drive start timing.	page 8 - 8
■	ATH timing	Sets the timing to start driving of the thread trimming motor.	page 8 - 9

NOTE 1: The state in which the embroidery machine is stopping after sewing a stitch or performing frame forward after data input.

2. SYSTEM INSTALLATION & SETTING

<input checked="" type="checkbox"/>	Jump conversion	Sets a jump code to be converted to a frame-stepping code, and sets the frame traveling method for frame stepping.	page 7 – 1
<input checked="" type="checkbox"/>	Automatic jump	Sets for automatic jumping.	page 7 – 4
<input checked="" type="checkbox"/>	Satin stitch conversion	Sets to extend the satin stitch width.	page 7 – 5
<input type="checkbox"/>	Software frame limit	Setting for checking whether or not a design is embroidered within the embroidery frame.	page 7 – 6
<input checked="" type="checkbox"/>	Low speed rpm	Sets the lowest rpm of the main shaft.	page 8 – 1
<input checked="" type="checkbox"/>	Number of start inching	Sets the number of times of inching at start.	page 8 – 2
<input checked="" type="checkbox"/>	Frame travel speed	Sets the frame travel speed for origin return, off-set feed, etc.	page 8 – 3
<input checked="" type="checkbox"/>	Upper thread breakage detection	Sets the upper thread breakage detection method.	page 8 – 4
<input checked="" type="checkbox"/>	ATH (automatic thread trimming)	Sets whether or not the ATH operates and the action when it operates.	page 8 – 5
<input type="checkbox"/>	Data edit <i>[NOTE 1]</i>	Modification, insertion, and deletion of stitch data, function code, etc. of design stored in memory.	page 9 – 1
<input checked="" type="checkbox"/>	Floppy disk processing	Writing design data stored in memory to a floppy disk, deleting a design from a floppy disk, and formatting a floppy disk.	page 10 – 1
<input checked="" type="checkbox"/>	Confirmation mode	Allows confirmation of current settings. * The confirmation in confirmation mode is enabled only in the normal display state (see page 2 – 7).	page 11 – 1
<input checked="" type="checkbox"/>	UTC (under thread breakage detection)	Sets the under thread breakage detection method.	page 12 – 2
<input type="checkbox"/>	BOR (boring)	Sets whether or not boring is performed, and the data processing method for boring.	page 12 – 3
<input type="checkbox"/>	COD (cording)	Sets whether or not cording is performed.	page 12 – 4
<input checked="" type="checkbox"/>	Network connection	Sets whether or not the network connection is made.	page 12 – 5

NOTE 1: Design data can be edited even when the design is being embroidered.

3. USING MENU KEY A

3. USING MENU KEY A



CAUTION

If design data is input when embroidering is being performed, the design being embroidered will be cancelled.

“Data input” is the procedure to set and input design data for embroidering.

The following four methods are used for inputting and setting data of embroidery designs.

- (1) Select designs stored in the memory of the embroidery machine.
→ Data Input (Memory): page 3 – 2
- (2) Select designs stored on a floppy disk (using the built-in FDD).
→ Data Input (Floppy Disk): page 3 – 3
- (3) Select designs from an FDD or reader connected to the PTR connector (see page 1 – 11).
→ Data Input (PTR): page 3 – 5
- (4) Select designs from an FDD or reader connected to the serial I/F connector (see page 1 – 11).
→ Data Input (Serial): page 3 – 7

3. USING MENU KEY A

3-1 Data Input (Memory)

Input a design data stored in memory to the machine.

<Procedure>

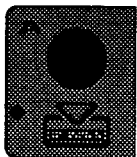

Press Menu key A until number **1** is displayed.

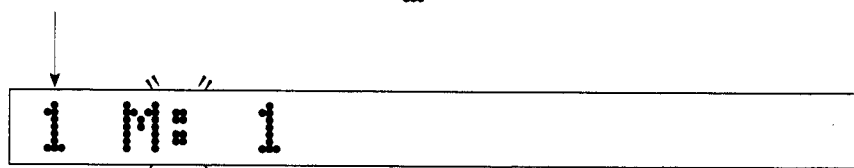

* The smallest design number of stored designs is displayed.



* When a design name is registered with the design number, that design name is also displayed.

Select a design number.

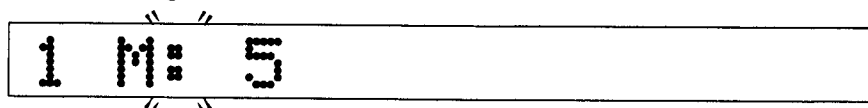

* Design number "5" is selected as an example here.

Press the SET key.

SET

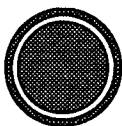

Setting is completed.

3. USING MENU KEY A

3-2 Data Input (Floppy Disk)

Input a design data stored in a floppy disk through the built-in FDD.

<Procedure>

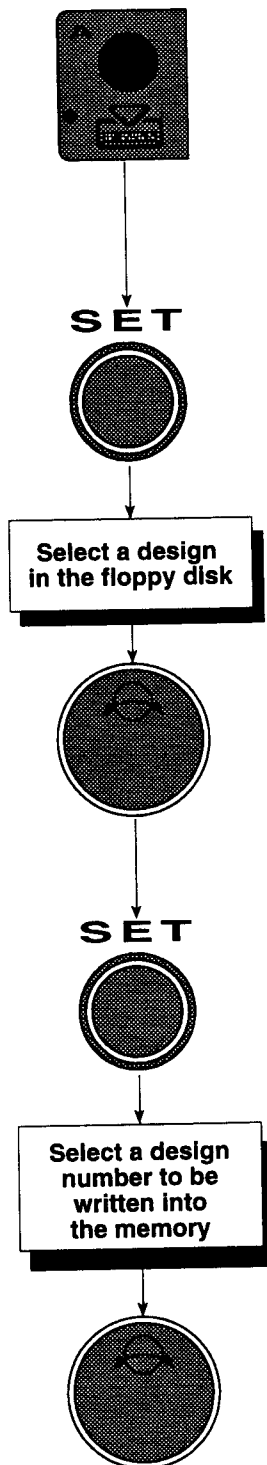

Press Menu key A until number **2** is displayed.

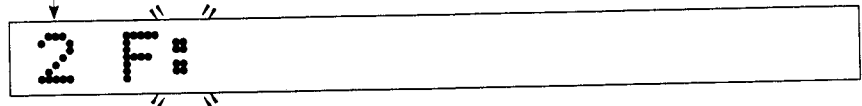

Press the SET key.



* The smallest design number of stored designs is displayed.

Select a design number.

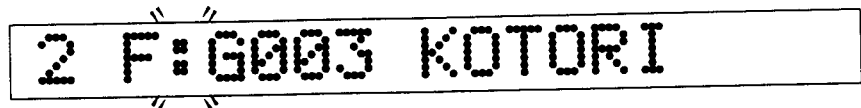

* Design number "G003" is selected as an example here.

Press the SET key.

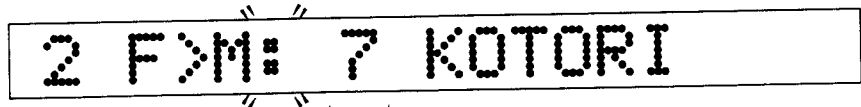

The smallest design number of unregistered numbers is displayed.

Select a design number.

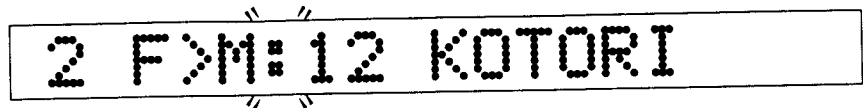

* Design number "12" is selected as an example here.

3. USING MENU KEY A



Press the SET key.

2 F>M: 12 KOTORI

When data writing is completed, the display switches to the normal state display (see page time 2 - 7).

The embroidery operation can be started.

3. USING MENU KEY A

3-3 Data Input (PTR)

Input a design data from an external device connected to the PTR connector.

<Procedure>

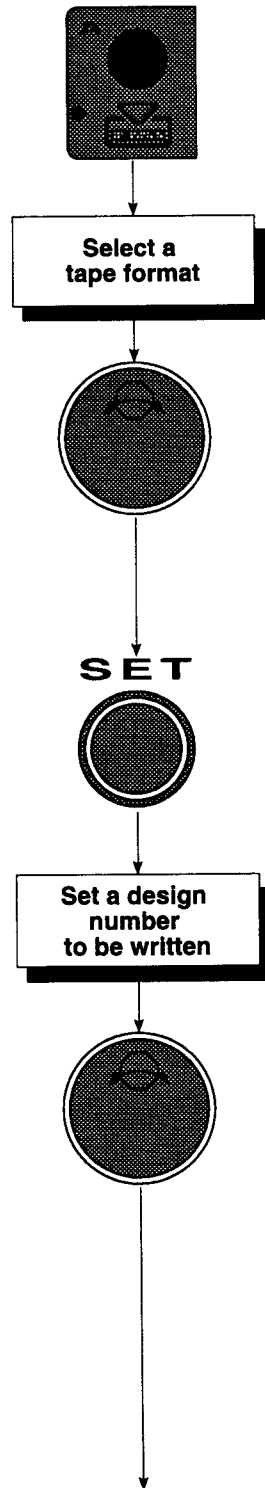

Press Menu key A until number 3 is displayed.

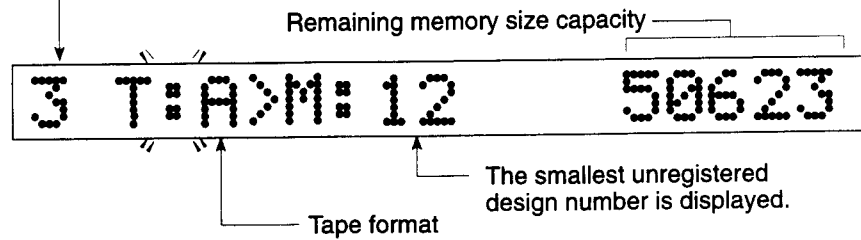

Select a tape format.

- A : Automatic select
- T : Tajima
- B : Barudan
- Z : ZSK



* "Tajima" is selected as an example here.

Press the SET key.

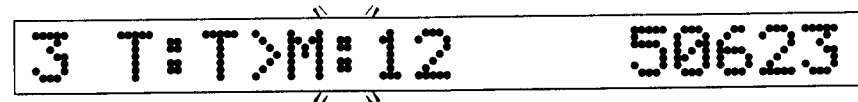

Select a design number (max. 99) to be written into the memory.

* When "-" is selected, tape operation (data is not written into the memory) is selected.

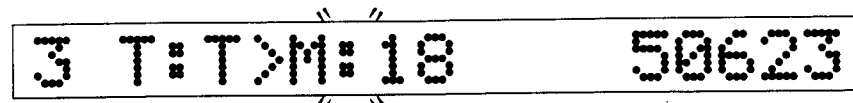

* Design number "18" is selected as an example here.

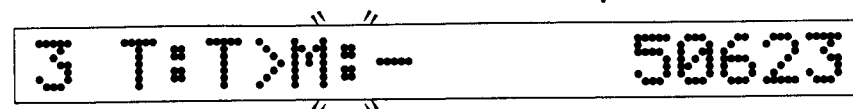

* Tape operation (data is not written into the memory) is selected as an example here.

3. USING MENU KEY A



Press the SET key. → The reader starts reading from the tape. *[NOTE 1]*

Setting is completed.

NOTE 1: When the tape operation has been selected, reading will be suspended and the operation panel display will switch to the "normal display" state (see page 2 – 7). Start embroidering in this state.

REMARK: When "data is written into the memory" has been selected, the operation panel display will switch to the "normal display" (see page 2 – 7) in the middle of writing. Embroidering can be started in the normal display state.

3. USING MENU KEY A

3-4 Data Input (Serial)

Input a design data from an external device connected to the serial I/F connector.

<Procedure>

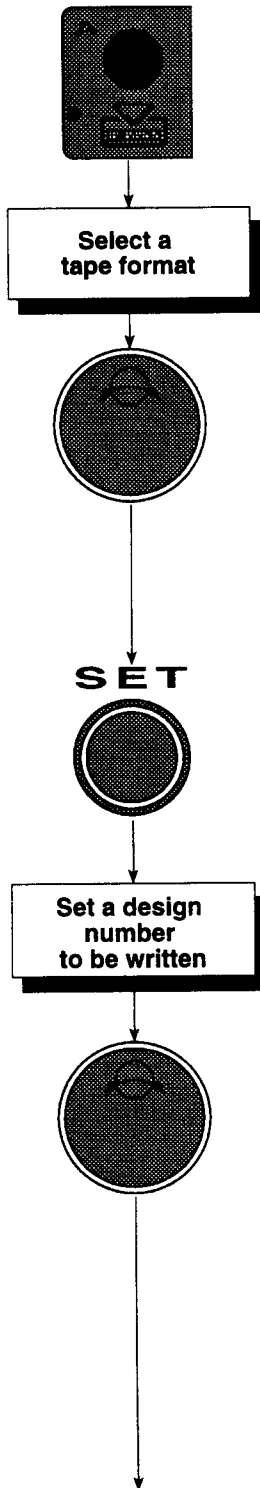

Press Menu key A until number 4 is displayed.

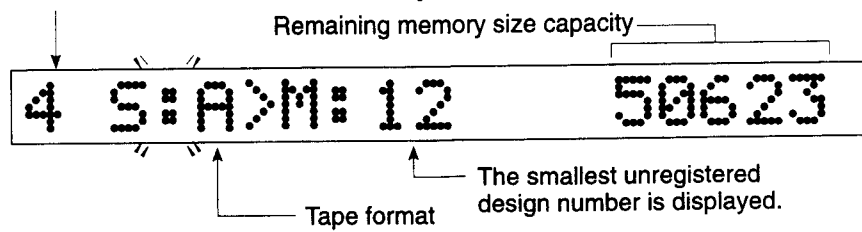

Select a tape format.

- A : Automatic select
- T : Tajima
- B : Barudan
- Z : ZSK



* "Tajima" is selected as an example here.

Press the SET key.

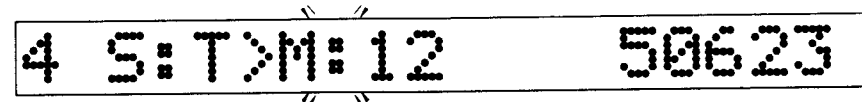

Select a design number (max. 99) to be written into the memory.

* When "-" is selected, tape operation (data is not written into the memory) is selected.

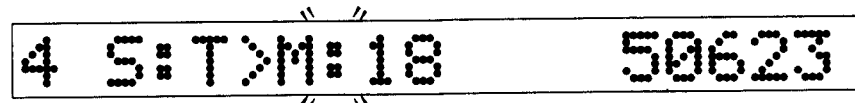

* Design number "18" is selected as an example here.

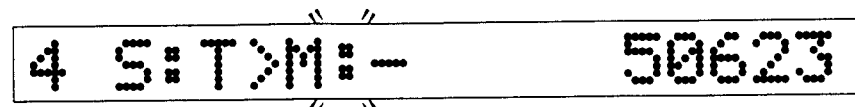

* Tape operation (data is not written into the memory) is selected as an example here.

3. USING MENU KEY A



Press the SET key. → The reader starts reading from the tape. *[NOTE 1]*

Setting is completed.

NOTE 1: When the tape operation has been selected, reading will be suspended and the operation panel display will switch to the "normal display" state (see page 2 – 7). Start embroidering in this state.

REMARK: When "data is written into the memory" has been selected, the operation panel display will switch to the "normal display" (see page 2 – 7) in the middle of writing. Embroidering can be started in the normal display state.

3. USING MENU KEY A

3-5 Memory Delete

Delete a design data stored in memory.

<Procedure>



CAUTION

Design data in memory cannot be deleted until the machine has finished the design.

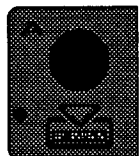

Press Menu key A until number **5** is displayed.

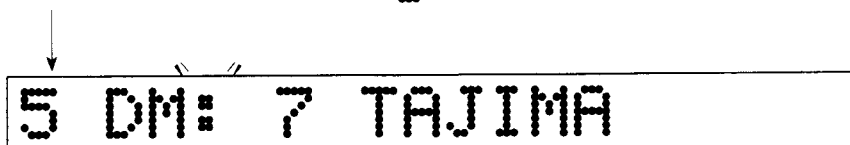

Display switches alternately.

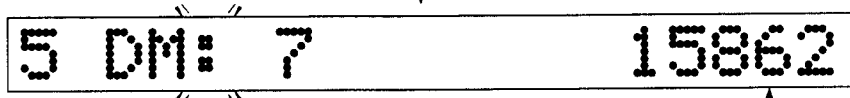

The number of stitches of the design

* When "Memory Delete" mode is entered, an alert is given by buzzer sound.

Select a design number to be deleted.

* Select "00" to delete all designs.



* Design number "18" is selected as an example here.

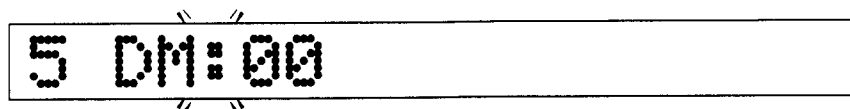

* All designs are deleted as an example here.

Press the SET key.

SET

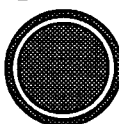

Setting is completed.

3. USING MENU KEY A

3-6 Standby Data Input (Outline of Standby Data Input Function)

The standby data input function allows the design data to be directly input ^[NOTE 1] to the memory from the optional external device connected to the machine.

The status in which standby data input is permitted is called the standby status and if the design data is input from the external device in the standby status, the data is automatically set.

NOTE 1: Standby data input is allowed when the data has not been set or when the machine has not been started or frame forward operation is not performed if the data has been set. Note that even in the standby data input permitted status, it is not allowed during color change operation (automatic, manual).

■ External devices used for standby data input

FM Note: To be connected to the serial interface (see page 1 – 11).

ML-50: To be connected to the serial interface (see page 1 – 11).

■ Remarks related to the standby data input

- Embroidering can be started when the preset time has elapsed after the start of standby data input (memory-direct operation, see page 3 – 13).

- Before inputting the data in the standby mode, make sure that there is sufficient free memory area to allow the input of the design data.

If the memory gets full during standby data input operation, an error occurs and data input is interrupted with error code [2BA] displayed. If this occurs while memory-direct operation is performed, further embroidering is disabled.

- When the machine status is switched between the normal status and standby data input status, a part of settings is replaced with the initial setting ^[NOTE 2] for the design data that is input first after the operation status change.

After the completion of standby data input, the settings for the design can be changed as required (not possible if the machine is running).

NOTE 2: The items for which the setting is replaced with the initial setting and the initial setting of them are indicated below.

Setting Items	Initial Settings
Data conversion	X: 100%, Y: 100%, rotation angle: 0°, mirror image: No
Repeat	X: 1, Y: 1, design interval: 0, priority: X, design interval function: frame step
Automatic offset	No
Software frame limit	OFF

3. USING MENU KEY A

■ Changing to the standby data input status

<Procedure>

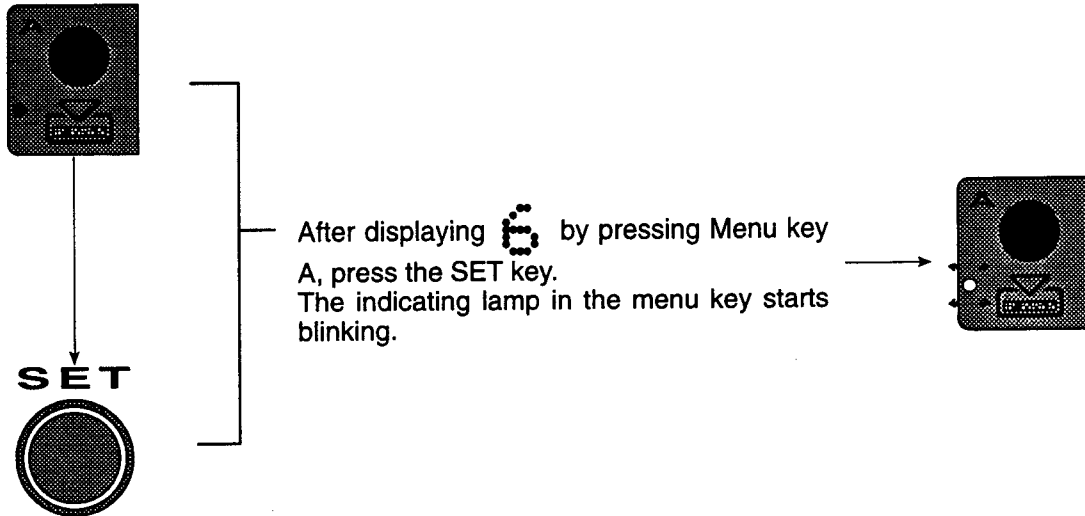

■ Canceling the standby data input status

To cancel the standby data input status, carry out either of the following after making sure that the "machine has stopped" and that "data is not being input in the standby data input status" [NOTE].

NOTE: If the data is being input, the indicating lamp in the Menu key A is blinking or off.

- Press the Menu key A while holding the SET key (see below).
- Input the data in other modes (memory, floppy disk, PTR, or serial). (see page 3 – 12)
- To cancel by pressing Menu key A while holding the SET key

<Procedure>

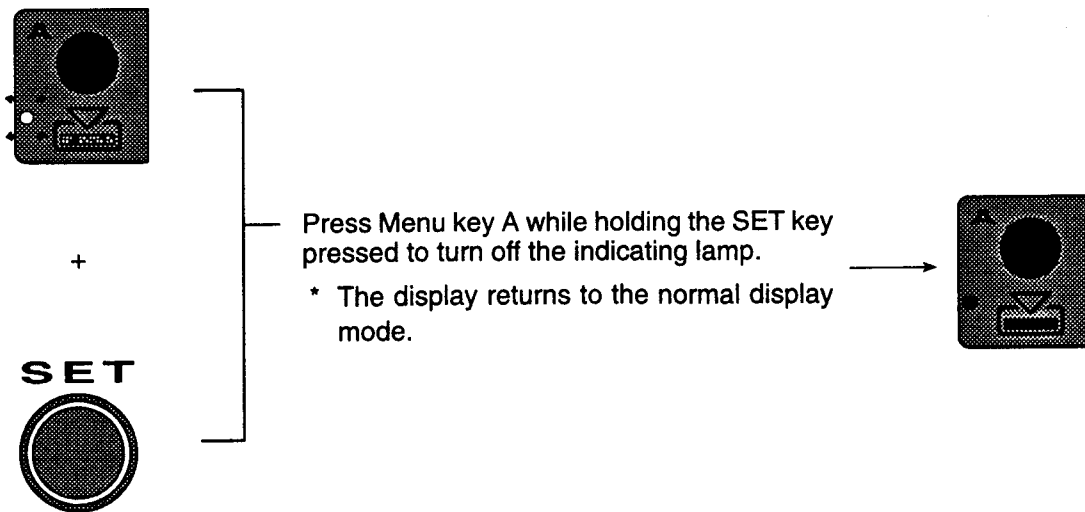

REMARK: When the standby data input status is canceled, the design data having been input in the standby data input mode are cleared and the machine enters the status where data input is not completed. (see page 2 – 7)

3. USING MENU KEY A

- To cancel by inputting the data in other modes (memory, floppy disk, PTR, or serial)

<Procedure>

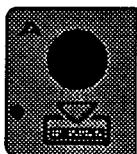

Press Menu key A until the screen number (1 to 4) that allows data input is displayed.



* Example when data input (memory) is selected:

Among the registered design numbers, the smallest design number is displayed. If the design name is registered, it is also displayed.

Select the design number.

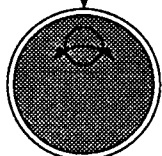

SET

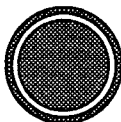

Press the SET key.

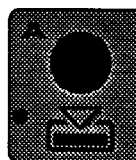

Upon completion of data input, the indicating lamp is turned off and the display returns to the normal display mode.

REMARK: When the standby data input status is canceled by inputting the data in other modes (memory, floppy disk, PTR, or serial), the data input in the selected data input mode is registered and the data having been input in the direct input status is cleared.

3. USING MENU KEY A

3-7 Standby Data Input

REMARK: Standby data input is allowed only when the data has not been set or when the machine has not been started or frame forward operation is not performed if the data has been set. Note that even in the standby data input permitted status, it is not allowed during color changing.

<Procedure>

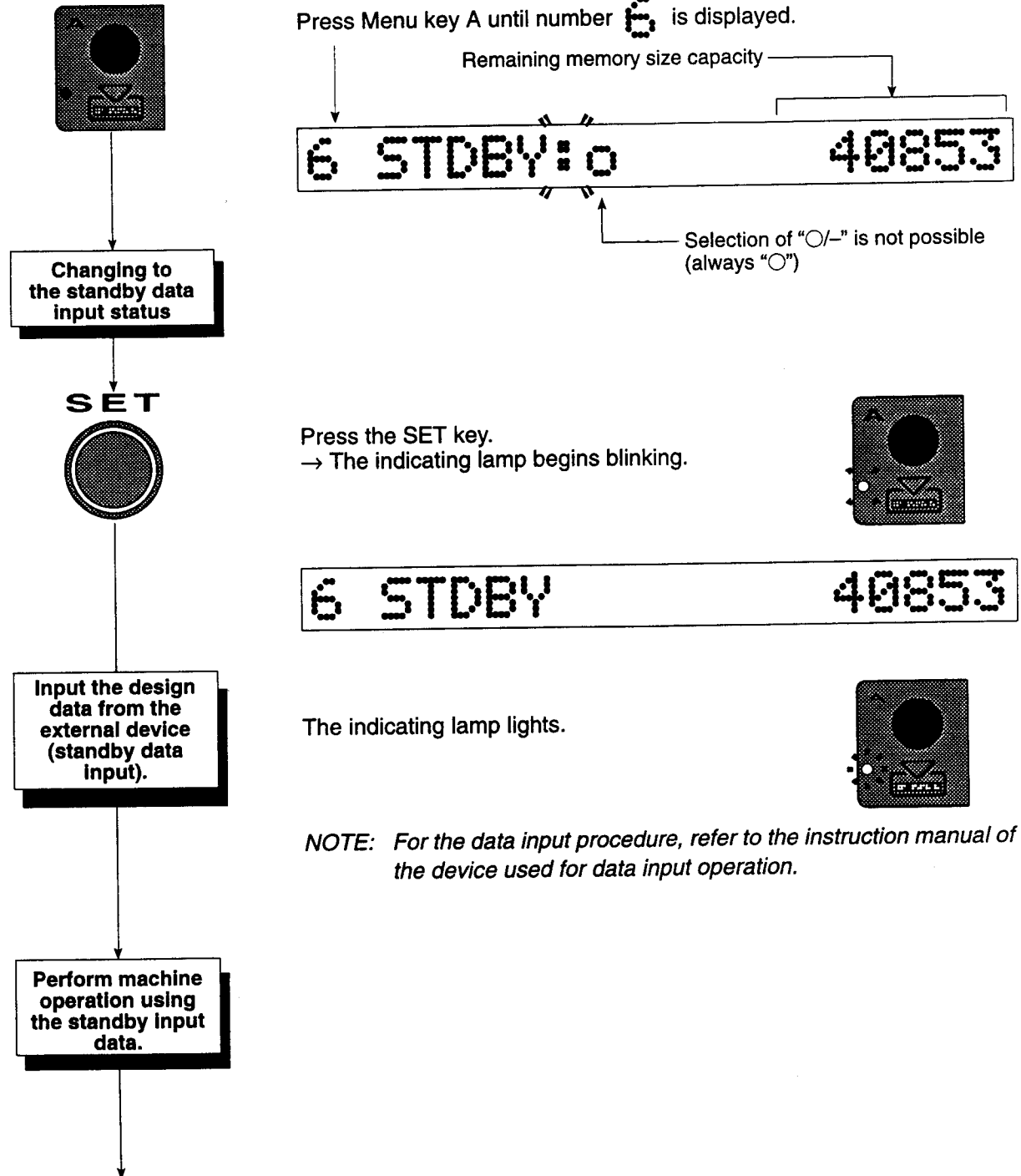

3. USING MENU KEY A

Memory-direct operation → Start embroidering [NOTE 1] if the display on the operation panel is changed to the one shown below.

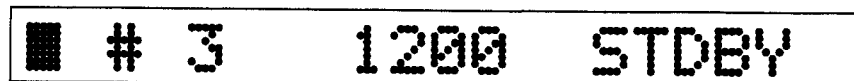

Speed display
Displays the presently set maximum speed.

Needle position display
Displays the presently selected needle bar number.

NOTE 1: The indicating lamp in Menu key A indicates the progress of data input and operation in the manner indicated below. Note that the next design data can be input when the indicating lamp starts blinking.

Design data is being input in the standby mode: Lit



After the completion of design data standby input: Unlit



After the completion of operation: Blinking

Operation after the completion of data input → Start the machine [NOTE 2] when the indicating lamp in Menu key A begins blinking.

NOTE 2: The indicating lamp in the menu key remains unlit while the machine is running. Upon completion of embroidery, the indicating lamp begins blinking. The next design data can be input from the external device when the indicating lamp begins blinking.

REMARK: If any of the following codes is displayed during data input, reset the machine by pressing the  key.

Code Nos.: 2B2, 2B3, 2B4, 2B5, 2BA, 3D1, 3D6

* When the machine is reset by this operation, the standby data input status is canceled and the design data already input in this status and the data having been input when the machine is reset are cleared.

4. USING MENY KEY B

4. USING MENU KEY B

4-1 Automatic Color Change/Automatic Start

Set the automatic/manual color change for a design and the automatic/manual start after color change.

4-1-1 Automatic Color Change

<Procedure>

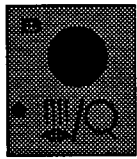

Press Menu key B until number **1** is displayed.

1 AC:0 AS:0

Select automatic or manual. : Automatic
 : Manual

1 AC:0 AS:0

* When "Automatic" is selected.

1 AC:- AS:0

* When "Manual" is selected.

SET

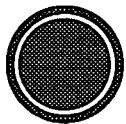

Press the SET key.

Setting is completed.

REMARK: If the SET key is pressed after selecting "manual", the following display is given and the setting for automatic start (see the next page) is not allowed.

1 AC:- AS:-

4. USING MENY KEY B

4-1-2 Automatic Start

<Procedure>

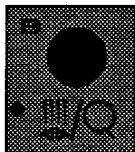

Set "Auto"
for automatic
color change

SET



Setting of
automatic/manual
start

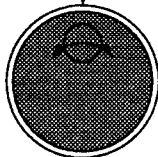

Press Menu key B until number **1** is displayed.

1 AC:0 AS:0

Set "Auto" for automatic color change.

Press the SET key.

1 AC:0 AS:0

* When automatic color change setting "AC" is "-", the Needle Bar Setting screen is not displayed.

Select automatic or manual. : Automatic
 : Manual

1 AC:0 AS:0

* When "Automatic" is selected.

1 AC:0 AS:-

* When "Manual" is selected.

4. USING MENY KEY B



Press the SET key.

Setting is completed.

* The AUTO/MANU start indicator lamp on the operation panel will turn on (automatic) or off (manual) according to the setting.

REMARK: When "automatic color change" has been set for "automatic", the operation mode will switch to "needle bar selection" (see page 4 - 4) setting mode regardless of the "automatic/manual start" setting.

4. USING MENY KEY B

4-2 Needle Bar Selection

Set the sequence of needle bars *[NOTE 1]* for automatic color change (see page 4 – 1).

NOTE 1: Needle numbers 10 and larger are displayed as follows.

10 → a, 11 → b, 12 → c

4-2-1 Example (1)

To set the sequence of needle bars for 3, 6, 12, 1

<Procedure>

Automatic color
change setting

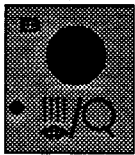

Step 1 needle
bar setting

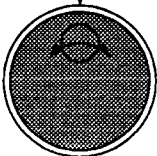

SET



Step 2 needle
bar setting

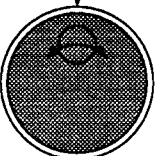

REMARK: When “manual color change” has been set, number 2 (shown below) will be skipped and number 3/Data convert will be displayed.

Press Menu key B until number 2 is displayed. (When color change is set to “Manual”, this screen is not displayed.)

2 NDL(01):

Select “3”.

2 NDL(01): 3

Press the SET key.

2 NDL(02): 3

Select “6”.

2 NDL(02): 36

4. USING MENY KEY B

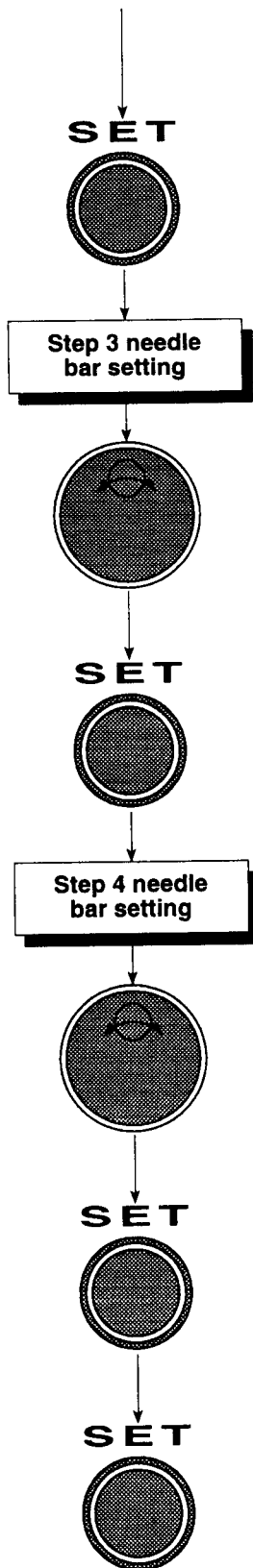

Press the SET key.

2 NDL(03): 36-----

Select "c".

2 NDL(03): 36c-----

Press the SET key.

2 NDL(04): 36c-----

Select "1".

2 NDL(04): 36c1-----

Press the SET key.

2 NDL(05): 36c1-----

Press the SET key.

2 NDL(01): 36c1-----

Setting is completed. (Operation can start.)

4. USING MENY KEY B

[To change setting]

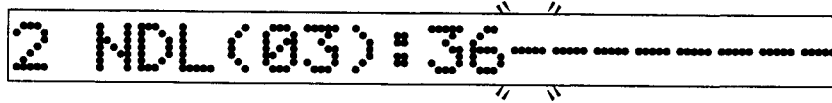

2 NDL(03): 36-----

* To change needle bar "6" of step 2 to "1" on this screen

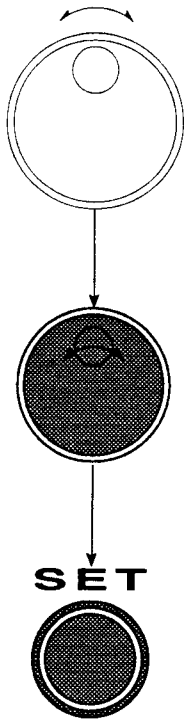

Turn jog dial B to display step 2 (02).

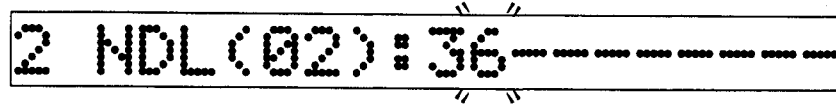

2 NDL(02): 36-----

Turn jog dial A to select "1".

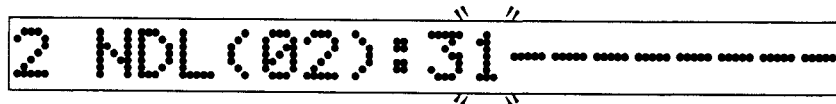

2 NDL(02): 31-----

Press the SET key.

4. USING MENY KEY B

4-2-2 Example (2)

To change setting of 3, 6, 2, 4, 7 to 2, 1, 3

<Procedure>

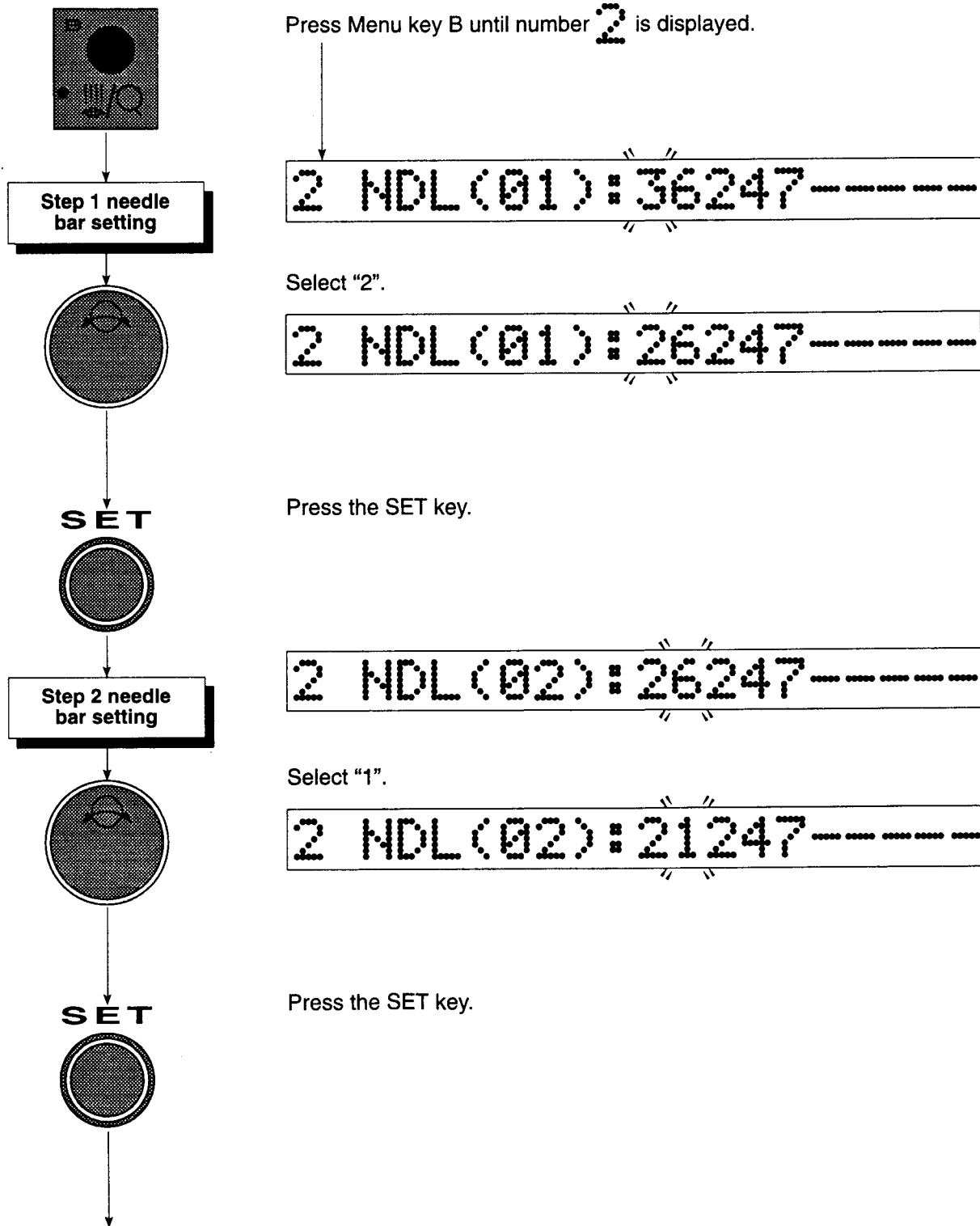

4. USING MENY KEY B

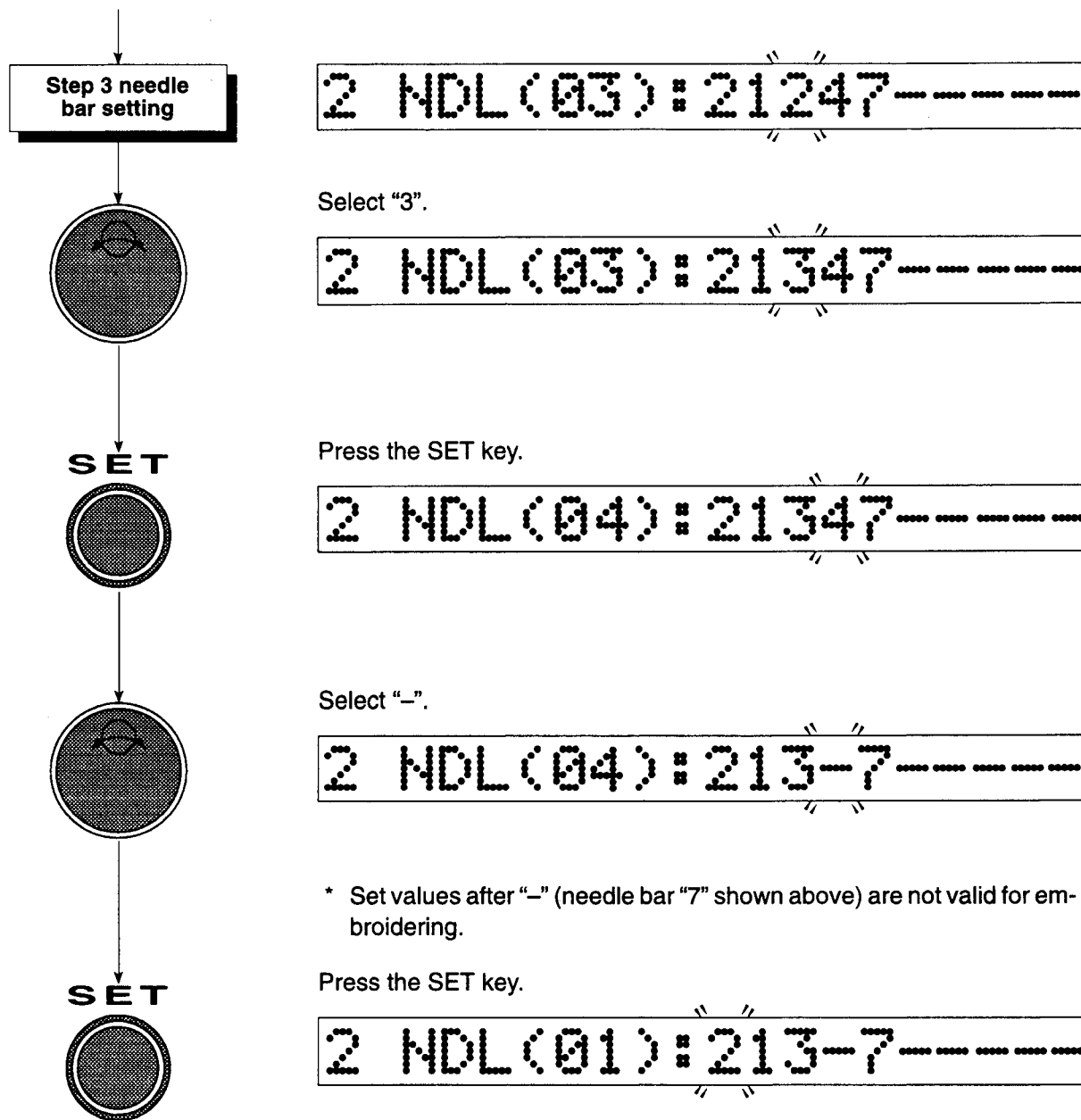

Setting is completed.

4. USING MENY KEY B

4-3 Data Conversion

The data conversion function allows input design data to be reduced, enlarged, rotated, and reversed as mirror images as described below.

- (1) Reduction and enlargement in the X and/or Y directions

A design can be reduced and enlarged independently in the X and Y directions within 50 to 200% range.

- (2) Rotation

A design can be rotated in 1° increments in the clockwise direction up to 359°.

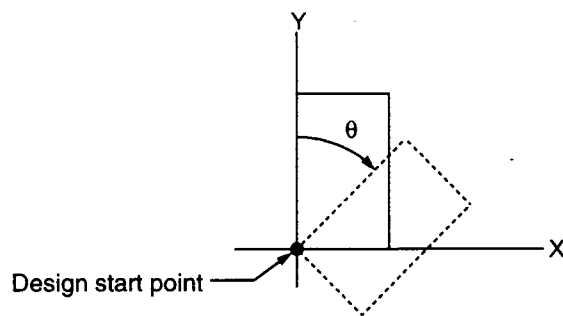

- (3) Mirror image conversion

A design can be reversed symmetrically about the Y axis.

[Examples]

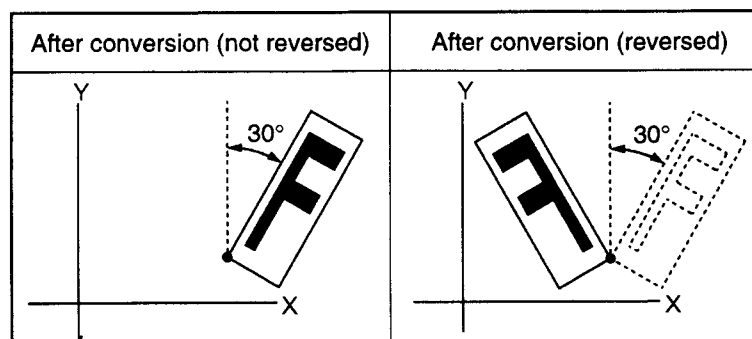
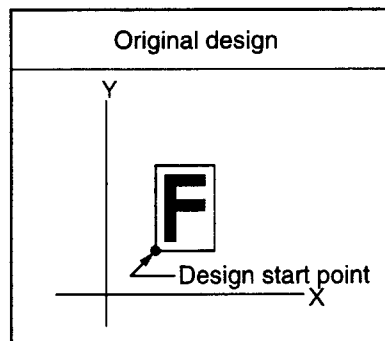

X scale : 100%
Y scale : 200%
Rotation angle: 30°

4. USING MENY KEY B

<Procedure>

REMARK: Data conversion cannot be done during embroidering.

Press Menu key B until number **3** is displayed.

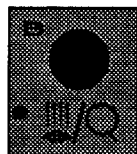

X-axis
scale setting

3 CNV X: 100 Y: 100

Select a scale factor (50 to 200).

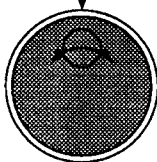

3 CNV X: 150 Y: 100

* "150" is selected.

SET

Press the SET key.



Y-axis
scale setting

3 CNV X: 150 Y: 150

* The set X-axis scale factor "150" is automatically input to the Y-axis scale factor.

Select a scale factor (50 to 200). (Only when setting a value different from the X-axis scale factor.)

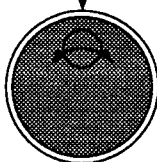

3 CNV X: 150 Y: 180

* "180" is selected.

4. USING MENY KEY B

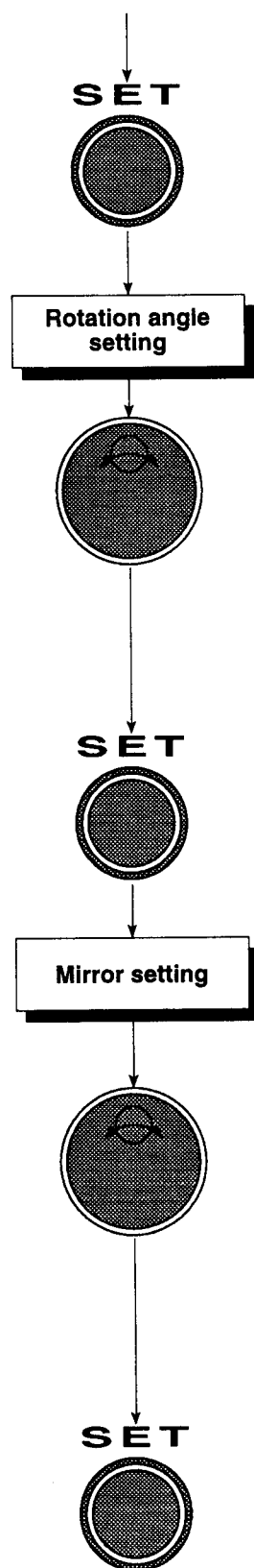

Press the SET key.

3 CHU R: 0 M: F

Select a rotation angle (0 to 359).

3 CHU R: 90 M: F

* "90" is selected.

Press the SET key.

3 CHU R: 90 M: F

Select mirror yes/no. F : No
 9 : Yes

3 CHU R: 90 M: 9

* "Yes" is selected.

Press the SET key.

Setting is completed.

4. USING MENY KEY B

4-4 Repeat

The repeat function allows a design to be repeated. The following three options are provided.

(1) Number of times of repetition

- In the X direction

Set the number of times of repetition in the right and left directions.
(setting range: 1 to 99)

- In the Y direction

Set the number of times of repetition in the front and back directions.
(setting range: 1 to 99)

(2) Design interval

- In the X direction

Set the design interval (between the design start points) by using a manual frame travel key or the jog dial.

+ : Repetition in the right direction

- : Repetition in the left direction

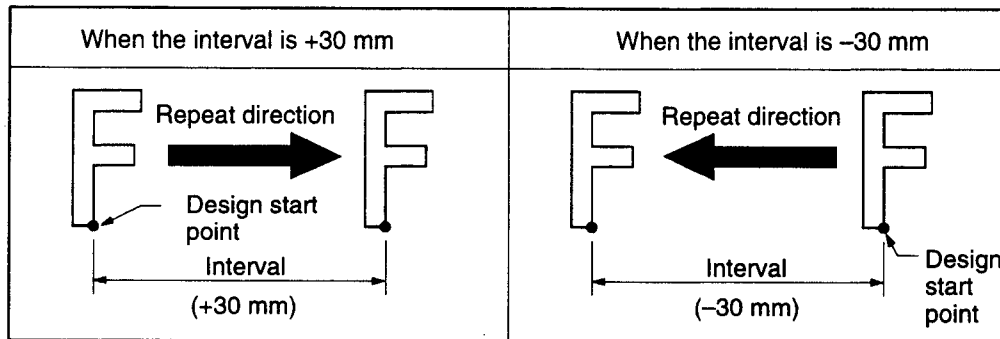

4. USING MENY KEY B

- In the Y direction

Set the design interval (between the design start points) by using a manual frame travel key or the jog dial.

- + : Repetition in the back direction
- : Repetition in the front direction.

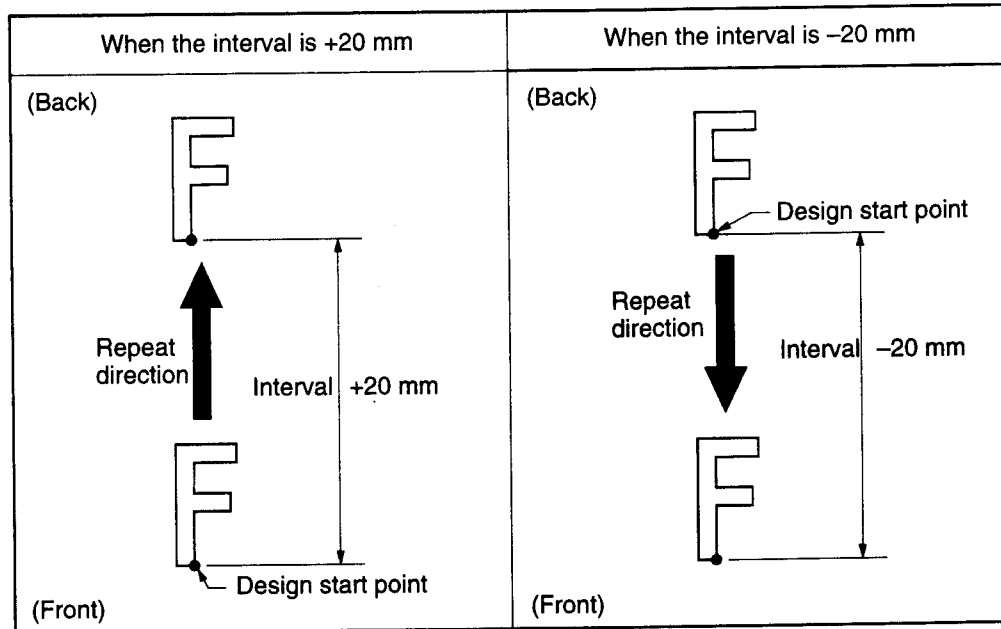

(3) X/Y repeat priority

- Set the priority of repetition in the X or Y direction.

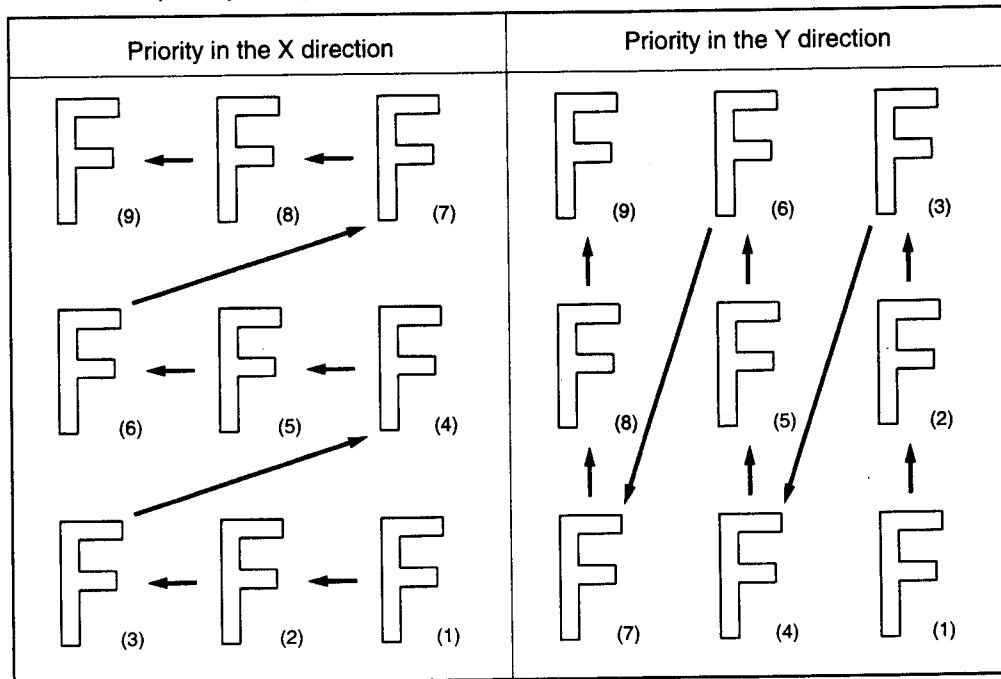

4. USING MENY KEY B

(4) Design interval function

Set whether the design interval is jumped by stitching or frame-stepping.

<Procedure>

REMARK 1: Repeat embroidery can be performed only with memory operation.

REMARK 2: Other settings except number of repetitions cannot be made during embroidering.

Press Menu key B until number 4 is displayed.

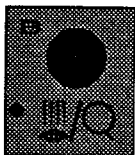

X-axis
repetition setting

4 REP X: 1 I: 0.0

Set the number of times of repetition (1 to 99).

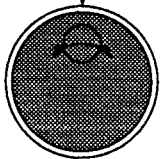

4 REP X: 10 I: 0.0

* "10" is selected.

SET

Press the SET key.

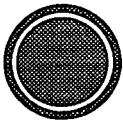

X-axis design
interval
designation

4 REP X: 10 I: 0.0

Designate the desired design interval by manual frame travel.

* The jog dial can also be used.

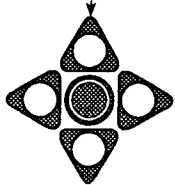

4 REP X: 10 I: + 150.0

SET

Press the SET key.

Design interval is displayed.

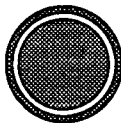

4. USING MENY KEY B

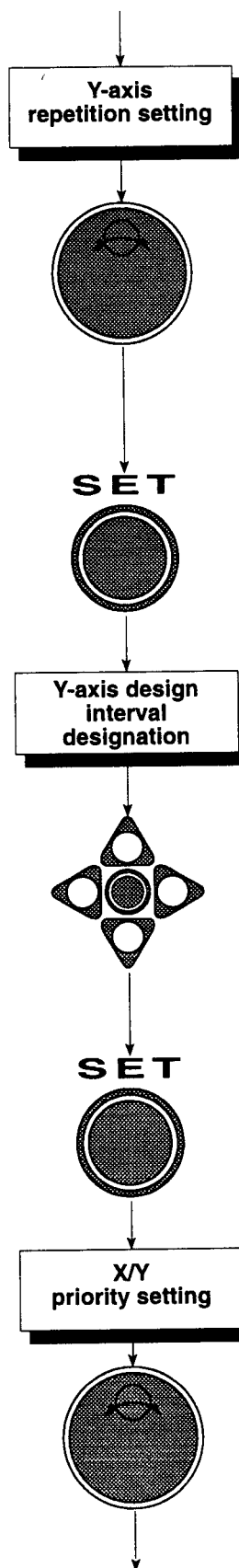

4 REP Y: 1 I: - 0.0

Set the number of times of repetition (1 to 99).

4 REP Y: 8 I: - 0.0

* "8" is selected.

Press the SET key.

4 REP Y: 8 I: - 0.0

Designate the desired design interval by manual frame travel.

* The jog dial can also be used.

4 REP Y: 8 I: + 55.0

Design interval is displayed.

Press the SET key.

4 REP P: X F: ↓

Select priority between X and Y. — X: X-axis priority
Y: Y-axis priority

4. USING MENY KEY B

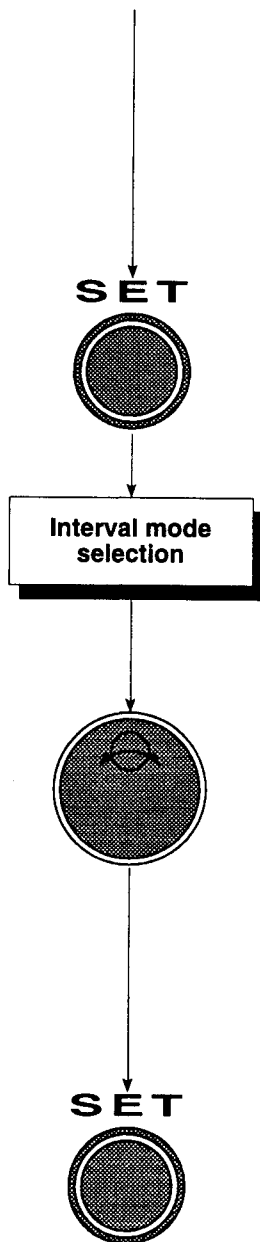

4 REP P:Y F:↓

* "Y-axis priority" is selected.

Press the SET key.

4 REP P:Y F:↓

Select the interval mode.

↓ : Stitch
↕ : Frame stepping

4 REP P:Y F:↕

* "Frame stepping" is selected.

Press the SET key.

Setting is completed.

4. USING MENY KEY B

4-5 Manual/Automatic Offset

The manual/automatic offset function is used to return the frame to the machine front side at the end point of embroidery or any designated point during embroidering. The following three options are provided:

- [Offset] — (1) Manual offset — (2) Automatic offset — (3) Automatic free setting offset

(1) Manual offset (See page 6 – 4 for the operation procedure.)

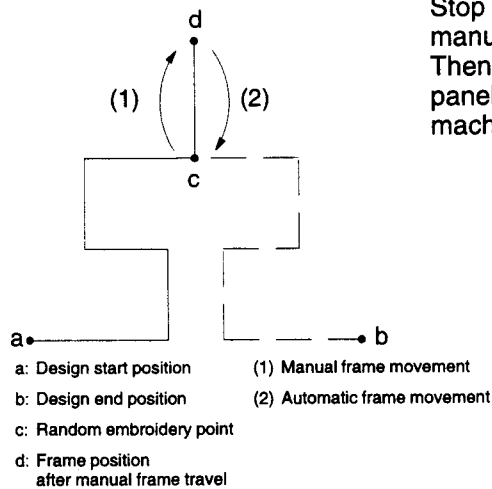

Stop embroidering at point c, move the frame manually to position d, and place appliques. Then, use the offset function to point c. When the machine is restarted, embroidering is continued.

(2) Automatic offset (See page 4 – 19 for the operation procedure.)

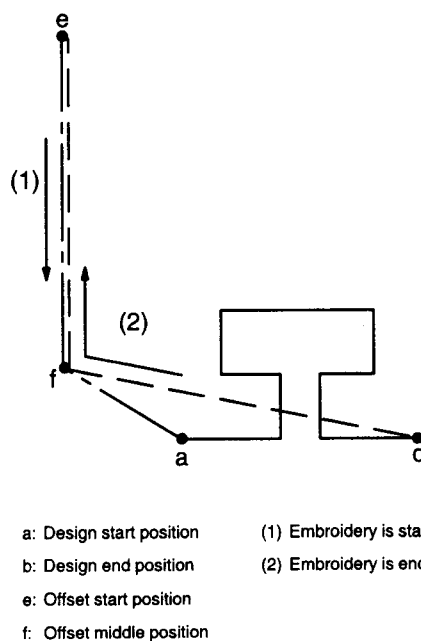

Set offset middle point f and offset start position e. When embroidering reaches design end position b and the thread is trimmed [NOTE 1], the frame returns to offset start position e via the offset middle position f. Change the frame and restart the machine. The frame moves to start position a via offset middle position f, and embroidering is started.

Start:
e → f → a → Embroidery starts.

Embroidery ends:
b → f → e

NOTE 1: When "○: ATH is used" has been set (see page 8 – 6).

4. USING MENY KEY B

(3) Automatic free setting offset (See page 4 – 20 for the operation procedure.)

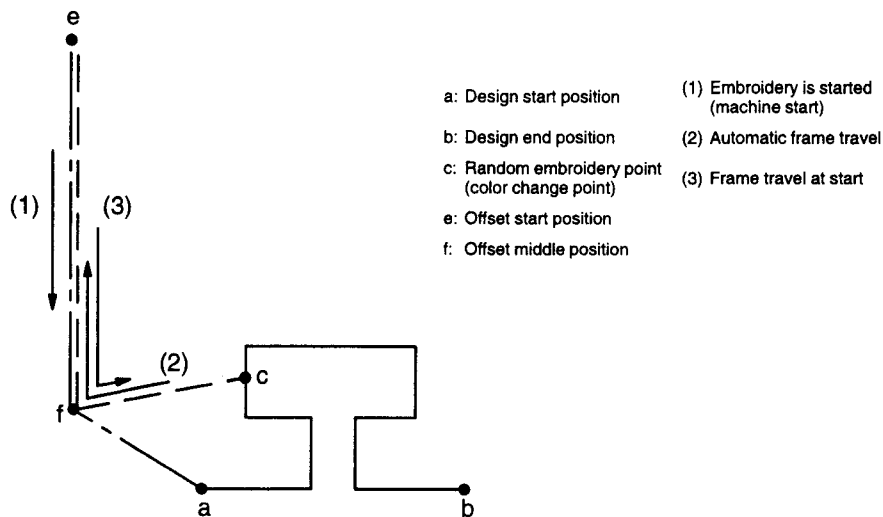

Set a point (point c) for executing automatic offset (color change) during embroidering by needle bar selection setting, and also set an offset middle position (position f) and an offset start position (position e) by automatic offset setting.

Thread trimming is executed *[NOTE 1]* at point c (color change point) and the frame moves to the offset start position via offset middle position f. Place appliques and restart operation. The frame returns to point c via offset middle position f and embroidering is continued. When embroidering is completed, the frame returns to the offset start position.

Initial start:

e → f → a → Embroidery starts.

When embroidered to point c:

c (trimming) → f → e

Restart:

e → f → c → Embroidering restarts.

Embroidery ends:

b → f → e

NOTE 1: When "○: ATH is used" has been set (see page 8 – 6).

4. USING MENY KEY B

4-6 Automatic Offset

Setting to move the frame to the machine front side when embroidering is completed.



WARNING

When manually moving the frame, do not place your hands or fingers on the machine table. If you put them on the machine table, you may be injured due to the moving frame.

<Procedure>

Move the frame to the start position of a design

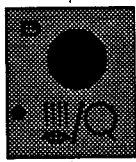

Offset middle position setting

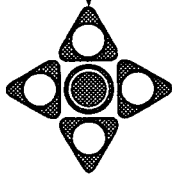

SET

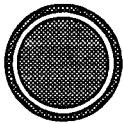

Offset start position setting

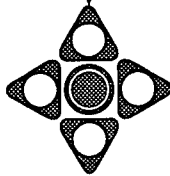

SET



Start position designation

REMARK: Automatic offset cannot be set during embroidering.

Press Menu key B until number 5 is displayed.

5 OF1 X:+ 0 Y:+ 0

Move the frame to a middle position by manual frame travel.

5 OF1 X:+370 Y:+ 291

Press the SET key.

5 OF2 X:+370 Y:+ 291

Move the frame to the offset start position by manual frame travel.

5 OF2 X:+540 Y:+ 169

Press the SET key. (Setting is completed.)

REMARK: This setting remains valid until the design (data) is changed or both the offset middle position and the start position are reset to "0".

4. USING MENY KEY B

4-7 Automatic Free Setting Offset

[Setting procedure]

- | | |
|---------------------------------|------------------|
| 1. Data input setting | See page 3 – 1. |
| 2. Needle bar selection setting | See page 4 – 4. |
| 3. Automatic offset setting | See page 4 – 19. |

Example:

When the applique design registered at design No. 3 is embroidered, contour stitching is done by using needle bar 3, pre-stitching after applique setting is done by using needle bar 3, and design stitching is done by using needle bar 5.

4-7-1 Data Input Setting

Perform data input of design number 3 (see page 3 – 1).

4-7-2 Needle Bar Selection Setting

<Procedure>

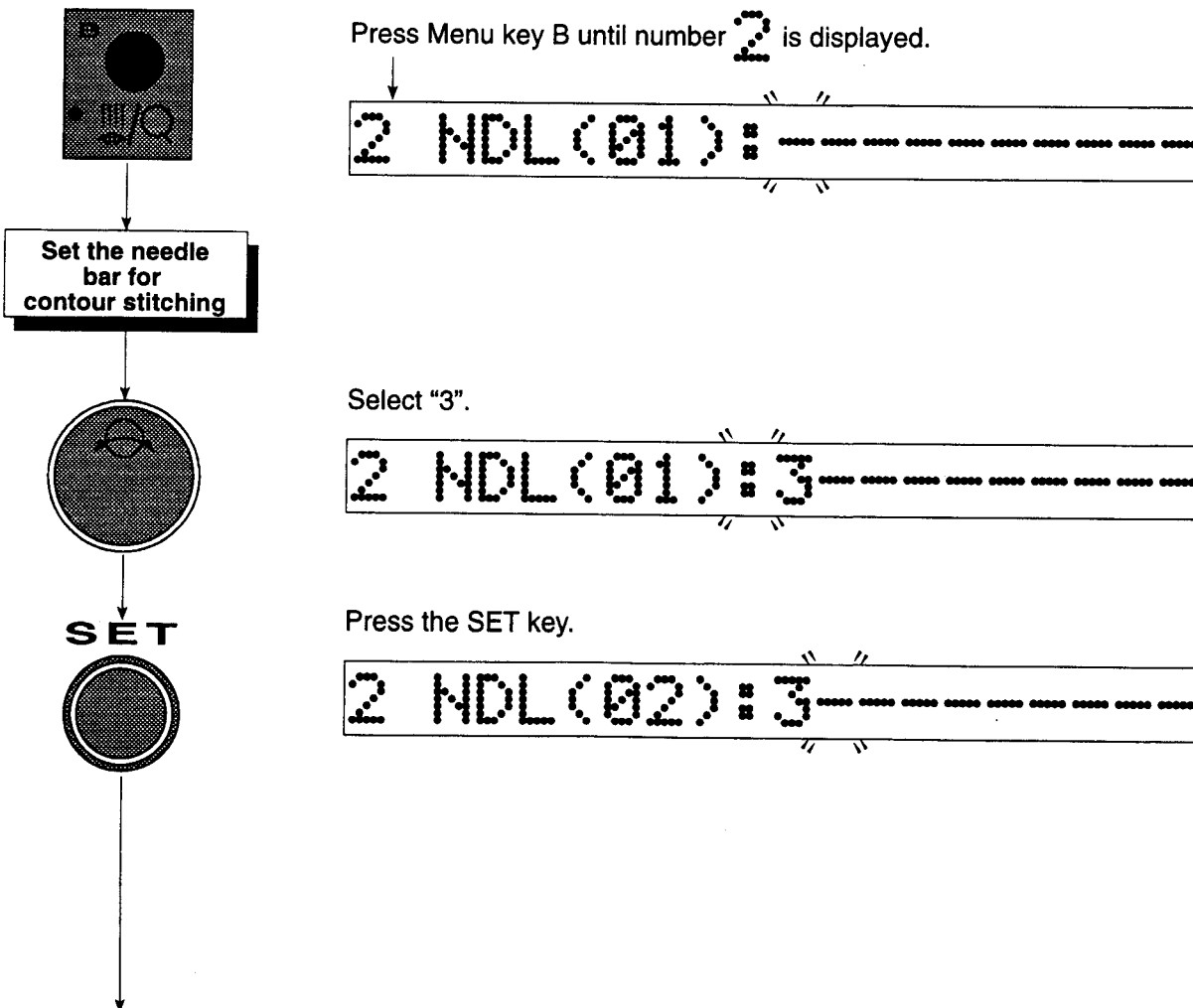

4. USING MENY KEY B

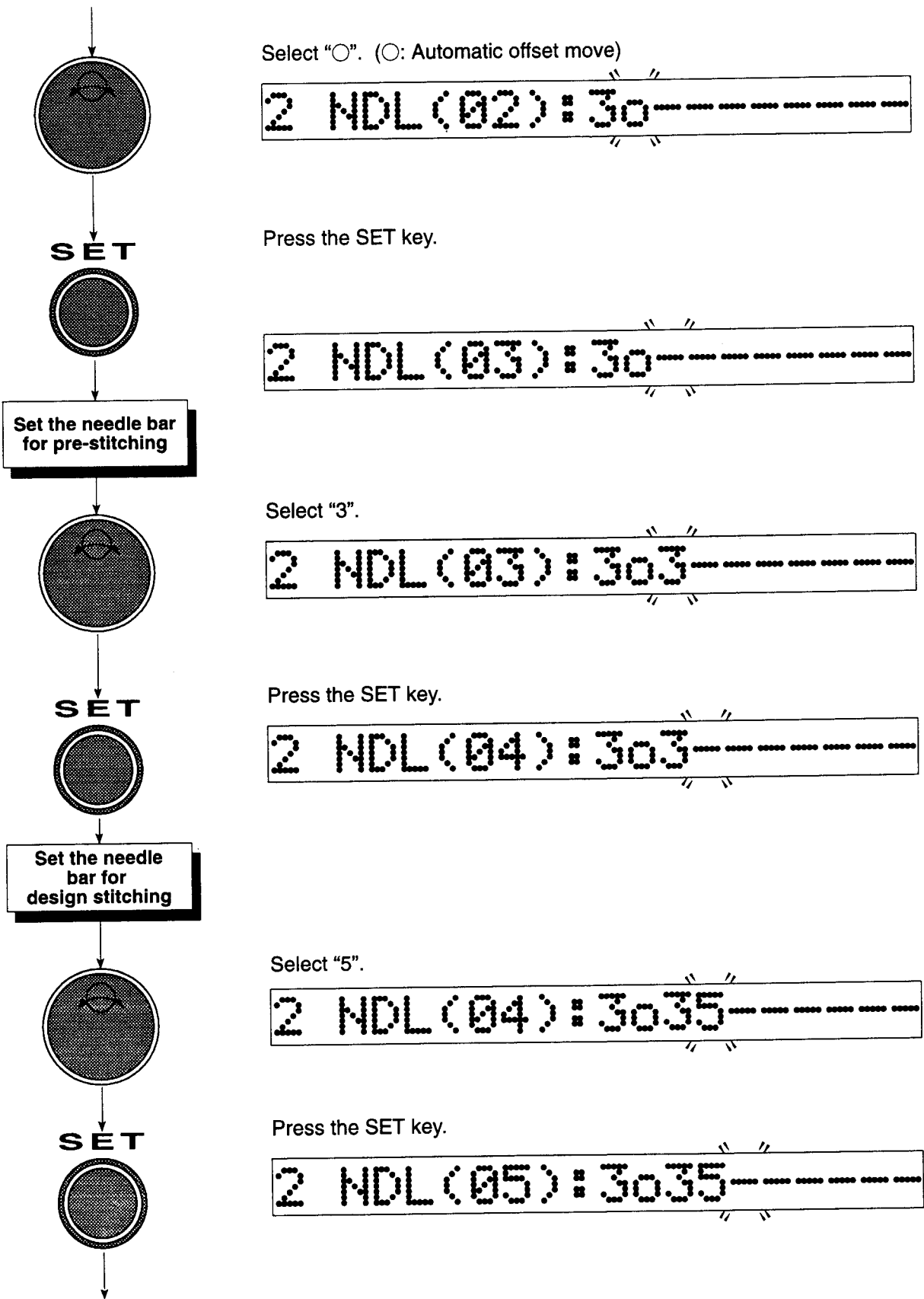

4. USING MENY KEY B



Press the SET key.

Setting is completed.

2 HDL(01): 3035-----

4-7-3 Automatic offset setting

Set the position where the frame is moved to the machine front side when contour stitching is completed (see page 4 – 19).

When the machine is started after completing the above settings, contour stitching is done by needle bar 3. When it is finished, trimming is done ^[NOTE 1] and the frame is moved to the machine front side. When the machine is started after setting appliques, the frame returns to the previous position and pre-stitching is done by needle bar 3, and then, design stitching is done by needle bar 5.

NOTE 1: When "○: ATH is used" has been set (see page 8 – 5).

5. USING MENU KEY C

5. USING MENU KEY C

5-1 Maximum RPM

Set the maximum rpm of the main shaft.

<Procedure>

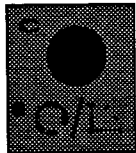

Press Menu key C until number **1** is displayed.

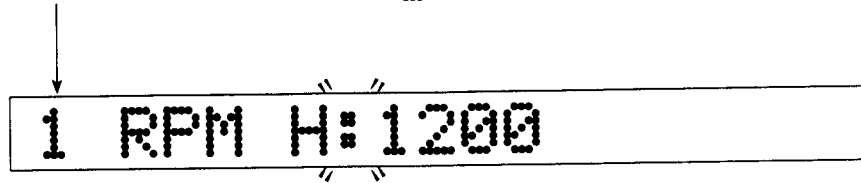

Select rpm (250 to 1200).

REMARK: The maximum rpm varies according to the embroidery conditions (type of the frame, thread, etc.)



* "1000" is selected as an example here.

Press the SET key.

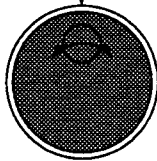

SET

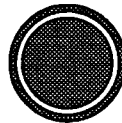

Setting is completed.

REMARK: The maximum rpm cannot be set to a value higher than the rpm set with the "maximum rpm limit" (see page 8 - 7).

5. USING MENU KEY C

5-2 Total Stitch Counter/Design Timer

The cumulative total of stitches and the time required for stitching a design are displayed.

■ Total stitch counter

<Procedure>

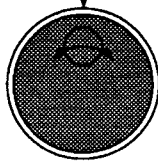
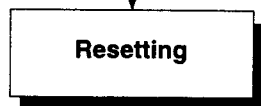
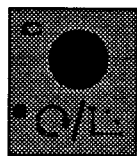

SET

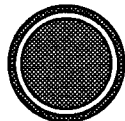

Press Menu key C until number 2 is displayed.

2 S: 28371 T: 3. 28. 45

Total number of stitches

Select "0".

Press the SET key.

2 S: 0 T: 3. 28. 45

■ Design timer

<Procedure>

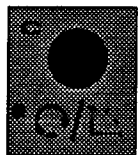

Press Menu key C until number 2 is displayed.

2 S: 14173 T: 0. 37. 25

37 minutes and 25 seconds have elapsed since the machine was started.

* The time monitoring is reset when a design is finished and the machine is started for the next operation.

5. USING MENU KEY C

5-3 Frame Back/Forward

Set the frame back/forward operation execution and the frame back/forward operation in color change units.

■ Setting the frame back/forward

<Procedure>

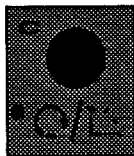

Press Menu key C until number 3 is displayed.

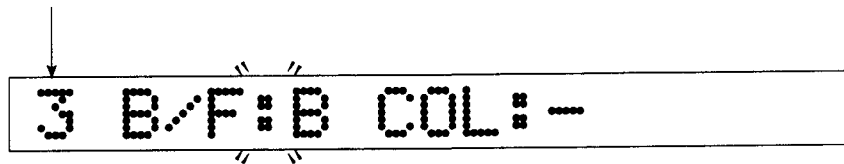

Select frame back/forward. B: Back
 F: Forward

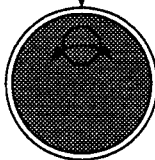

* "Forward" is selected.

SET

Press the SET key.

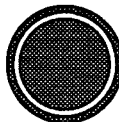

Setting is completed. — when only the frame back/forward is set

* The frame back/forward setting indicator lamp on the operation panel will turn on (frame back) or off (frame forward) according to the setting.

REMARK: When the machine stopped due to thread breakage when this is set for "Forward", setting is automatically made for "Back" temporarily.

Go to (1) on the next page for setting the frame back/forward in color change units.

5. USING MENU KEY C

5-4 Frame Back/Forward in Color Change Units

 CAUTION

When performing this operation, do not place your hands or fingers on the machine table. If you put them on the machine table, during frame back/forward operation, you may be injured due to the moving frame.

<Procedure>

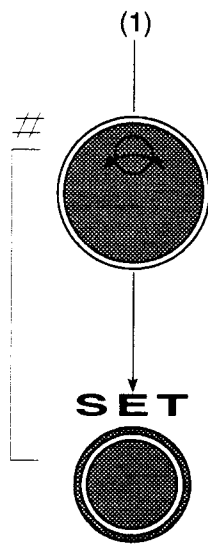

Select "0".

3 B/F:F COL:0

Press the SET key.

The frame is moved forward for one color change unit.

3 B/F:F COL:-

* To move the frame forward further, repeat the procedure indicated by "#" shown above.

5. USING MENU KEY C

5-5 Automatic Origin Return

This sets whether or not the frame is returned automatically to the design start point (*NOTE 1*) when the embroidery is finished.

<Procedure>

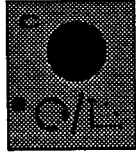

SET



Press Menu key C until number 4 is displayed.

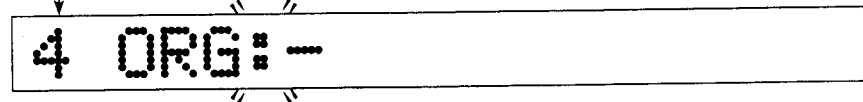

Select Yes or No. : Yes
: No

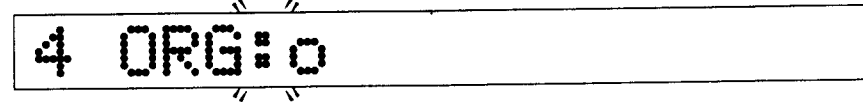

* "Yes" is selected as an example here.

Press the SET key.

Setting is completed.

NOTE 1: "Design start point" is the position where start or frame forward was made for the first time after data input. However, when "automatic offset" has been set, the "offset start position" (see page 4 - 17) will become the design start point.

5. USING MENU KEY C

5-5 Automatic Origin Return

This sets whether or not the frame is returned automatically to the design start point (*NOTE 1*) when the embroidery is finished.

<Procedure>

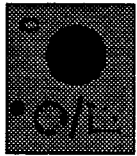

SET

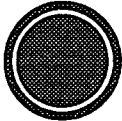

Press Menu key C until number 4 is displayed.

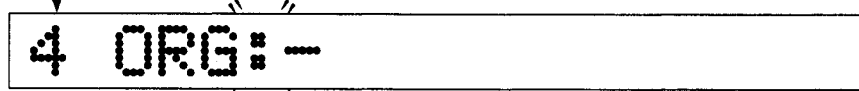

Select Yes or No. : Yes
: No

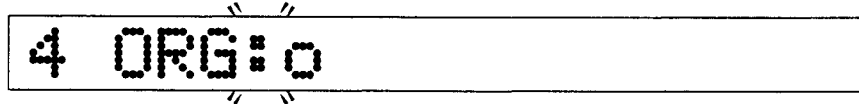

* "Yes" is selected as an example here.

Press the SET key.

Setting is completed.

NOTE 1: "Design start point" is the position where start or frame forward was made for the first time after data input. However, when "automatic offset" has been set, the "offset start position" (see page 4 - 17) will become the design start point.

6. USING MENU KEY D

6. USING MENU KEY D

6-1 Manual Color Change

Manually slide the needle bar case and perform color changing.



CAUTION

When performing this operation, do not put your hands near the needle bar case. If your hand is near the needle bar case, you may be injured by the sliding needle bar case.

<Procedure>

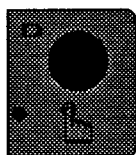

Press Menu key D until number **1** is displayed.



1 M_NDL: 3

Select a needle bar number.

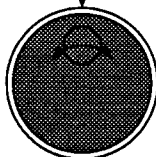

1 M_NDL: 8

* "8" is selected as an example here.

SET

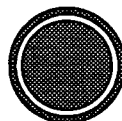

Press the SET key. → The needle bar case slides [NOTE]

NOTE: While the needle bar case is sliding, "■" lights in the display and it starts blinking after the completion of slide (color change).

REMARK: To execute embroidering according to "manual color change" setting, set "automatic color change" (see page 4 - 1) for "manual".

6. USING MENU KEY D

6-2 Manual ATH

Manually operate the ATH to trim the thread.



WARNING

When performing this operation, do not put your hands under the needle or on the machine table. If your hand is under the needle or on the machine table, you may be injured by the needle or the frame which moves during thread trimming.

<Procedure>

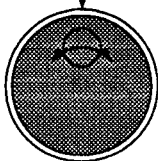
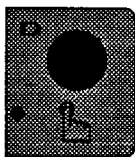

SET

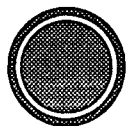

Press Menu key D until number 2 is displayed.

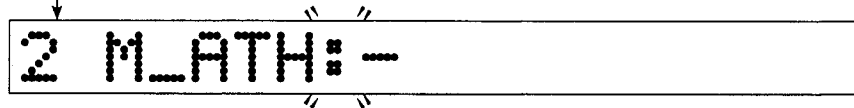

REMARK: When "○: ATH is used" has not been set with the ATH settings (see page 8 - 5), "○" will not be displayed though the jog dial is turned. Make setting to use the ATH before setting the manual ATH operation.

Select "○".

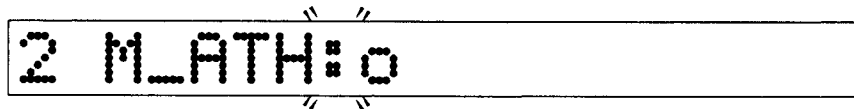

* An alert is given by buzzer sound.

REMARK: The needle moves and thread is trimmed immediately when the SET key is pressed.

Press the SET key.

The ATH operates.

6. USING MENU KEY D

6-3 Manual Origin Return

This operation makes the frame manually return from current position to the design start (origin) point [NOTE 1].



CAUTION

When performing this operation, do not place your hands or fingers on the machine table. If you put them on the machine table during this operation, you may be injured due to the moving frame.

<Procedure>

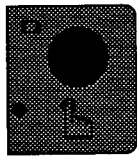

SET

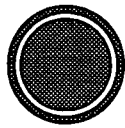

Press Menu key D until number 3 is displayed.

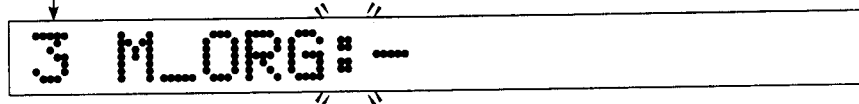

Select "O".

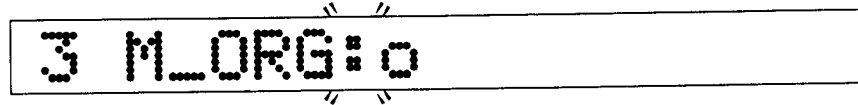

* An alert is given by buzzer sound.

REMARK: The frame moves immediately when the SET key is pressed.

Press the SET key.

The frame returns to the origin of the design.

NOTE 1: "Design start point" is the position where start or frame forward was made for the first time after data setting.
However, when "automatic offset" has been set, the "offset start position" (see page 4 - 17) will become the design start point.

6. USING MENU KEY D

6-4 Manual Offset

This operation is used to return the frame to the original position after moving the frame by manual frame traveling or manual origin return.



CAUTION

When performing this operation, do not place your hands or fingers on the machine table. If you put them on the machine table during this operation, you may be injured due to the moving frame.

<Procedure>

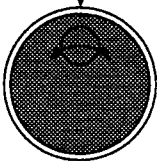
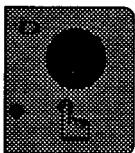

SET

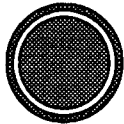

Press Menu key D until number 4 is displayed.

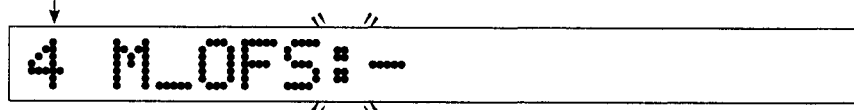

Select "O".

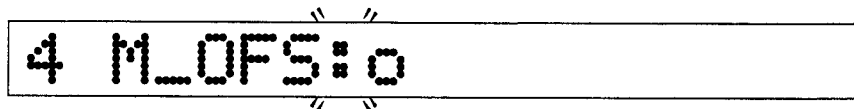

* An alert is given by buzzer sound.

REMARK: The frame moves immediately when the SET key is pressed.

Press the SET key.

The frame will return to the point prior to manual frame travel.

SUPPLEMENT: If the frame was moved by manual frame traveling from an offset start position (see page 4 – 17), the frame will return to the offset start position by the operation mentioned above.

6. USING MENU KEY D

6-5 Manual Frame Traveling

This operation allows to manually move the frame by using switches. The following two methods are provided.

- Using the manual frame travel keys



CAUTION

When performing this operation, do not place your hands or fingers on the machine table. If you put them on the machine table during this operation, you may be injured due to the moving frame.

<Procedure>

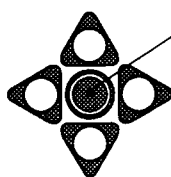

Selects high/low speed of frame traveling.

* High/low speed switches every time this key is pressed.

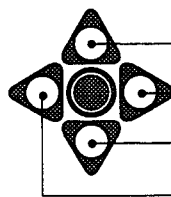

Back

Right

Front

Left

Traveling direction

6. USING MENU KEY D

■ Using the jog dial



CAUTION

When performing this operation, do not place your hands or fingers on the machine table. If you put them on the machine table during this operation, you may be injured due to the moving frame.

<Procedure>

Select X/Y travel direction

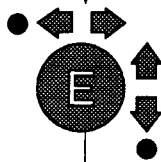

Press the key so that the travel direction indicator lamp lights.

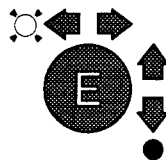

The frame moves in the X (right and left) direction.

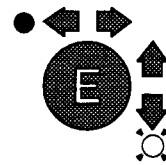

The frame moves in the Y (front and back) direction.

Frame travel

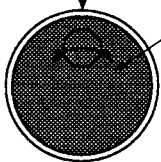

Jog dial A (inside)

In the X direction

Clockwise : Right

Counterclockwise : Left

} The frame moves at low speed.

In the Y direction

Clockwise : Back

Counterclockwise : Front

} The frame moves at low speed.

OR

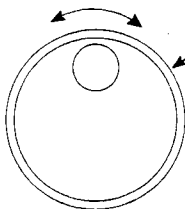

Jog dial B (outside)

In the X direction

Clockwise : Right

Counterclockwise : Left

} The frame moves at high speed.

The frame moves at high speed.

In the Y direction

Clockwise : Back

Counterclockwise : Front

} The frame moves at high speed.

REMARK: The X/Y indicator lamps go off when a menu key or a function key is pressed, and the input value can be selected by using the jog dial.

7. USING THE F1 KEY

7. USING THE F1 KEY

7-1 Jump Conversion

This sets the number of stitches of jump code data with which those data are converted to a frame stepping code.

Also, the frame movement method (batch process/according to data) at frame stepping (NOTE 1: page 7 - 3) is set.

<Procedure>

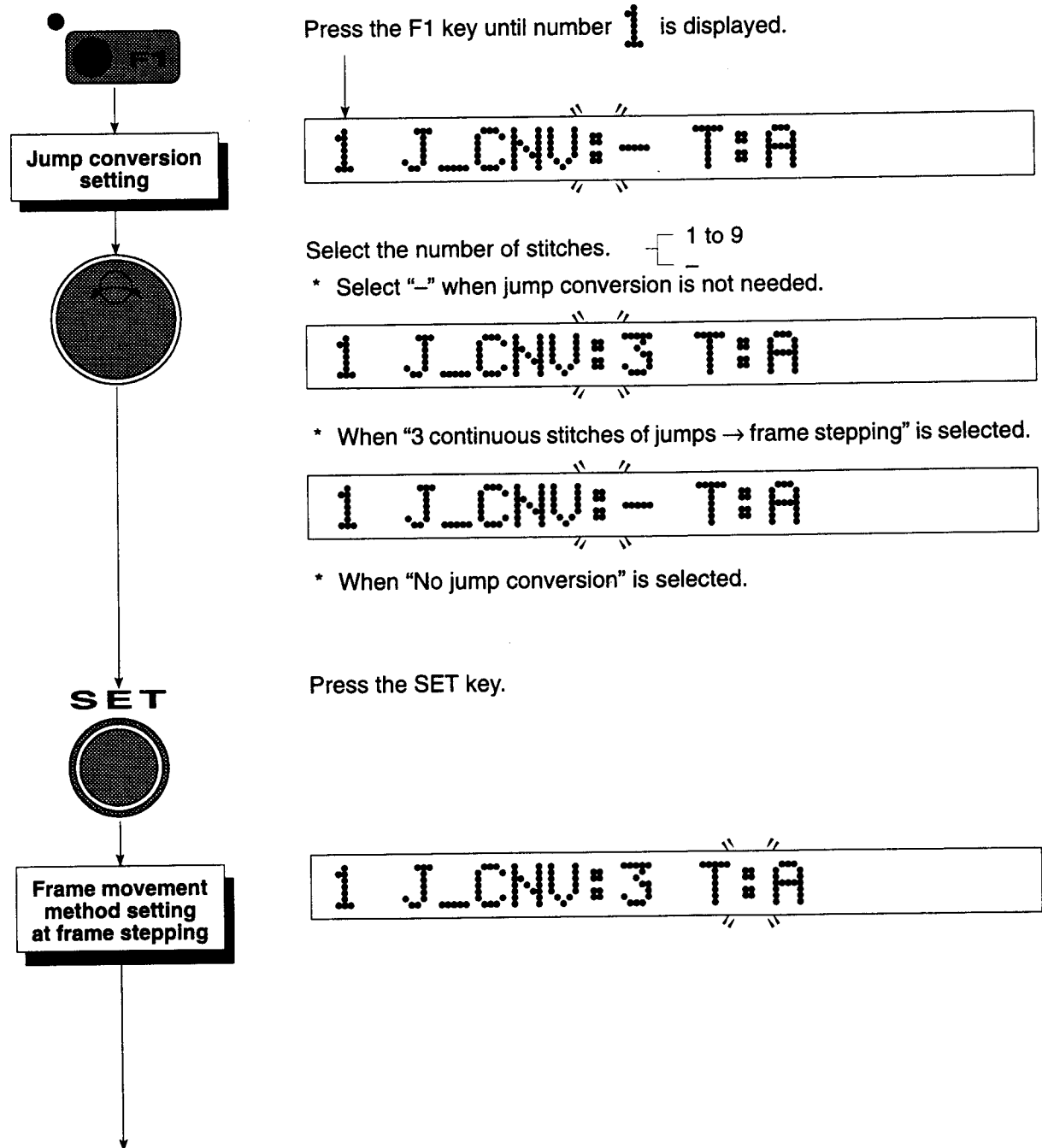

7. USING THE F1 KEY

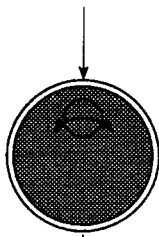

Select "A" or "B".

A: Continuous frame stepping by batch process

B: Stitch-by-stitch frame stepping according to data

1 J_LCHU:3 T:B

"According to data" is selected as an example here.

SET

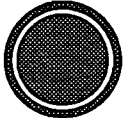

Press the SET key.

Setting is completed.

7. USING THE F1 KEY

NOTE 1: Frame movement methods (batch process/according to data)

Difference in frame movement when continuous jump is executed is as shown below.

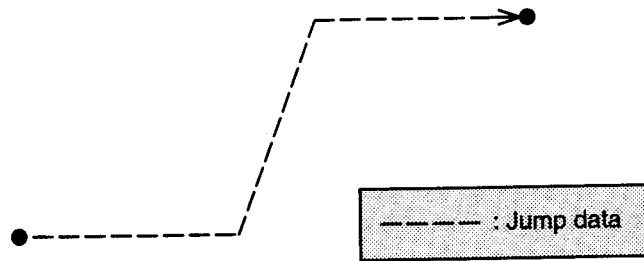

- Batch process

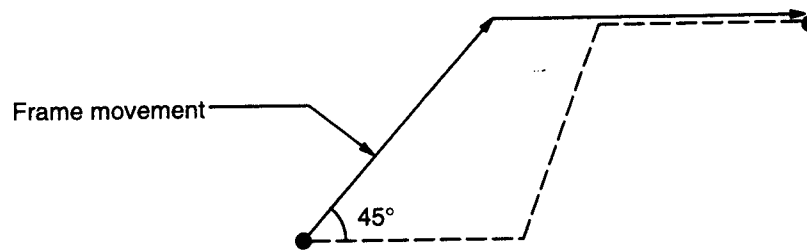

- According to data

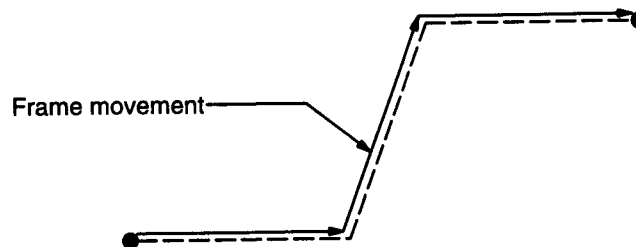

REMARK: To execute automatic frame detachment [NOTE 2], set for "according to data".

NOTE 2: After embroidering is finished, the frame automatically moves and the embroidery frame (sock frame, etc.) is detached from the base frame.

7. USING THE F1 KEY

7-2 Automatic Jump

Setting for executing automatic jumps when a stitch length is longer than set stitch length.

<Procedure>



Press the F1 key until number 2 is displayed.

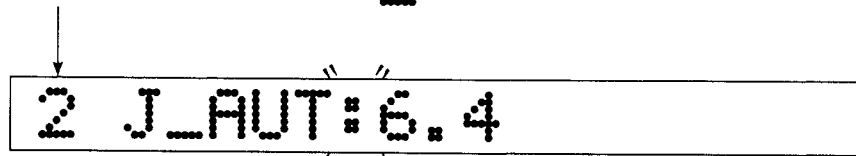

Select the stitch length to execute automatic jump. [4.0 to 9.9 (mm)
-]

* Select "-" when automatic jump is not needed.

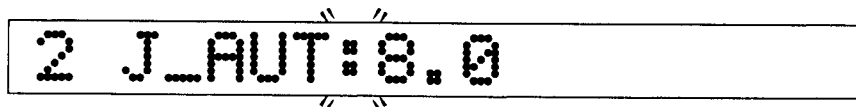

* "8.0" (mm) is selected as an example here.

SET

Press the SET key.

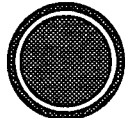

Setting is completed.

7. USING THE F1 KEY

7-3 Satin Stitch Conversion

Setting for expanding the width of satin stitches:

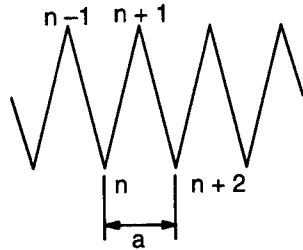

* Only when distance a between the "n"th stitch and "n+2"th stitch is less than 1 mm, the distance can be expanded.

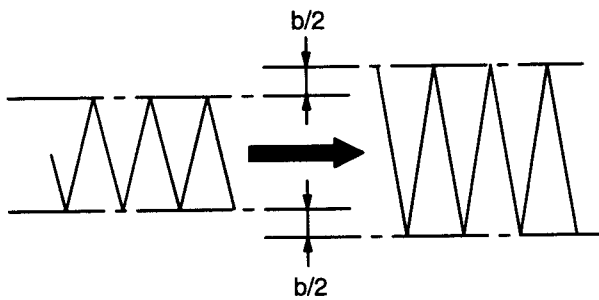

* Half the expansion amount b is added to both sides of the satin stitch width.

* Expansion amount setting range is 0.1 to 1 mm.

<Procedure>



Press the F1 key until number 3 is displayed.

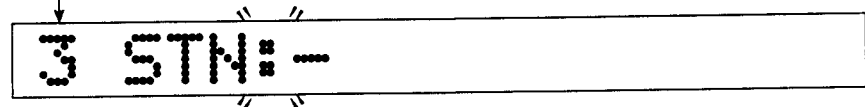

Select the expansion amount. [0.1 to 1.0 (mm)]

* Select "-" when an expansion is not needed.

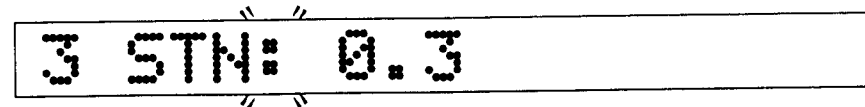

* "0.3 (mm)" is selected as an example here.

Press the SET key.

SET

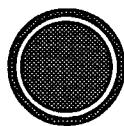

Setting is completed.

7. USING THE F1 KEY

7-4 Software Frame Limit

Setting for stopping the machine *[NOTE 1]* operation before a needle hits the frame when a design is larger than the frame or when the start point is incorrectly set.

Set the frame shape (embroidery space) by manual frame travel before starting embroidering.



CAUTION

When manually moving the frame, do not place your hands or fingers on the machine table. If you put them on the machine table while moving the frame manually, you may be injured due to the moving frame.

<Procedure>

REMARK: Software frame limit setting cannot be made during embroidering.



Press the F1 key until number **5** is displayed.

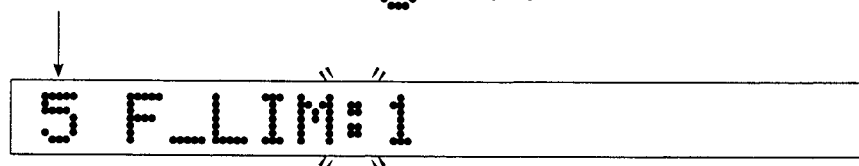

Select the frame shape. — 1: Square frame
— 2: Round (Circle)
— 3: Other (polygon)



- "1: Square frame" is selected → page 7 - 8 (A)
- "2: Round (Circle) frame" is selected → page 7 - 9 (B)
- "3: Other (polygon, oval) frame" is selected → page 7 - 12 (C)

NOTE 1: When the machine is stopped by the software frame limit detection, press the



key to reset.

7. USING THE F1 KEY

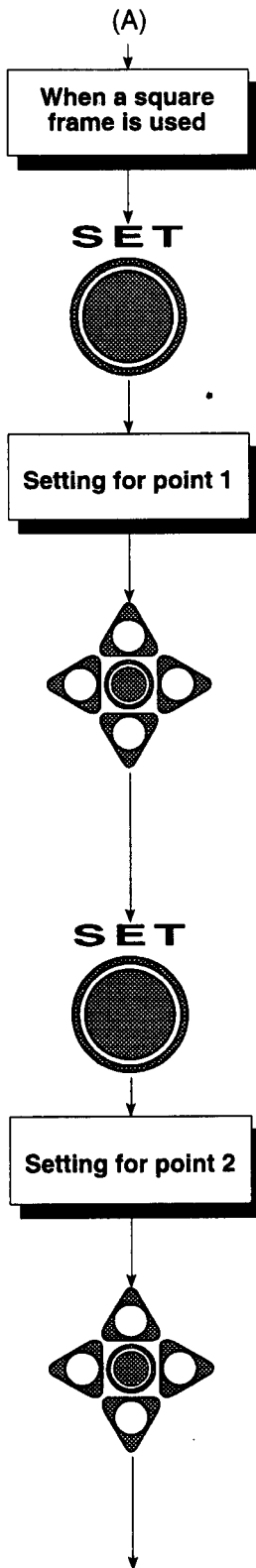

5 F LIM: 1

Press the SET key.

5 FL1 01:

Align a stitch point in a corner of the square frame by manual frame travel. (Point 1)

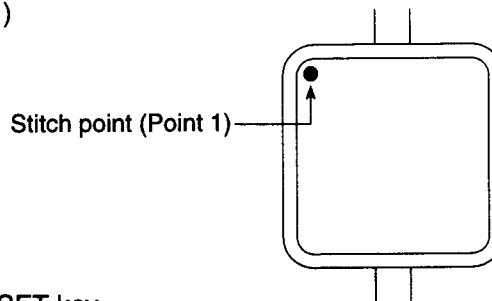

Press the SET key.

5 FL1 02: + 0 + 0

Align another stitch point in the diagonal corner of the square frame by manual frame travel. (Point 2)

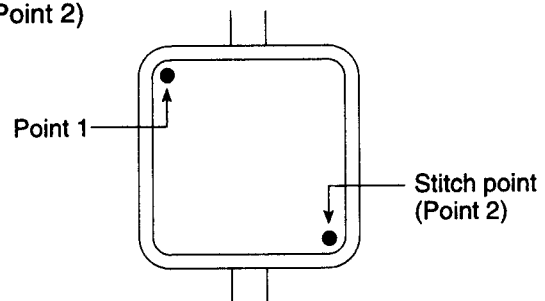

7. USING THE F1 KEY

5 FL1 02: +300 - 300

X coordinate Y coordinate

The X-Y coordinates referring to Point 1 are displayed in mm.

SET



Press the SET key.

Setting is completed.

* The above setting inputs a software frame shape as follows.

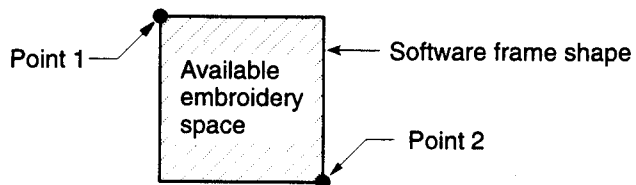

(B)

When a round frame is used

SET



Setting for point 1

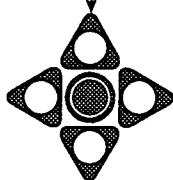

5 F_LIM: 2

Press the SET key.

5 FL2 01:

Align a stitch point with a point in the round frame by manual frame travel. (Point 1)

Stitch point (Point 1)

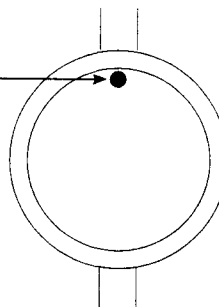

7. USING THE F1 KEY

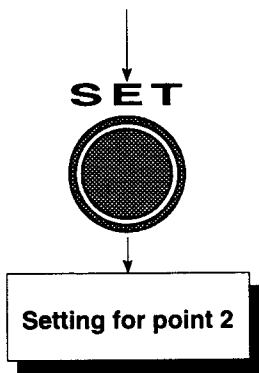

Press the SET key.

5 FL2 02: + 0 + 0

Align another stitch point with a point (an apex of a regular triangle as much as possible) in the round frame by manual frame travel. (Point 2)

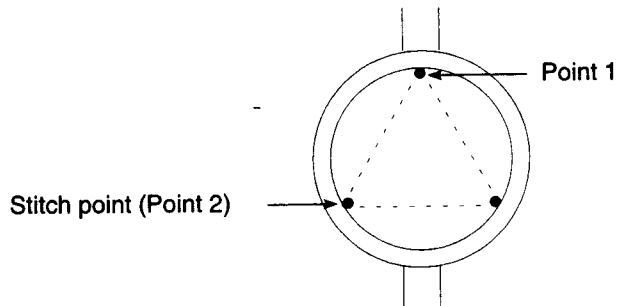
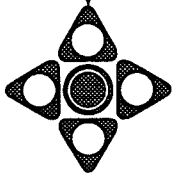

5 FL2 02: -144 - 250

X coordinate Y coordinate
 The X-Y coordinates of Point 2 referring to Point 1 (0, 0) are displayed in mm.

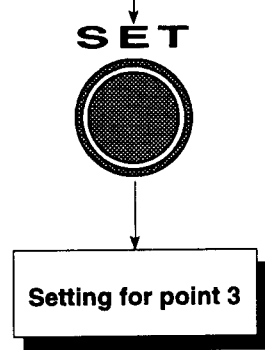

Press the SET key.

5 FL2 03: -144 - 250

7. USING THE F1 KEY

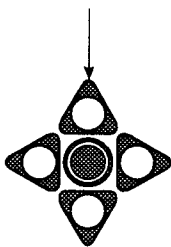

SET

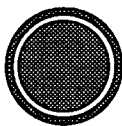

Align another stitch point with a point (an apex of a regular triangle as much as possible) in the round frame by manual frame travel. (Point 3)

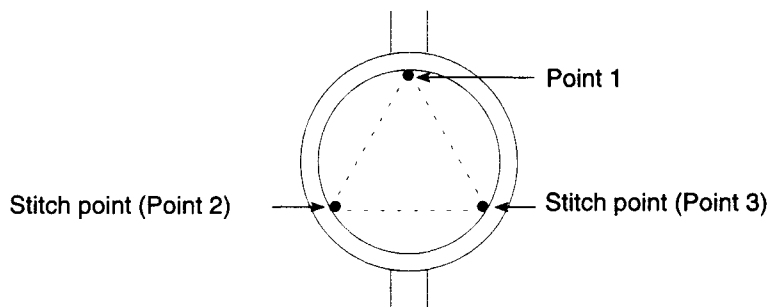

5 FL2 03: +144 - 250

X coordinate | Y coordinate

The X-Y coordinates of Point 3 referring to Point 1 (0, 0) are displayed in mm.

Press the SET key.

Setting is completed.

* The above setting inputs a software frame shape as follows.

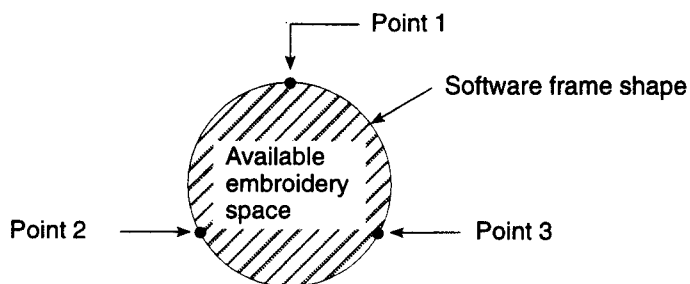

7. USING THE F1 KEY

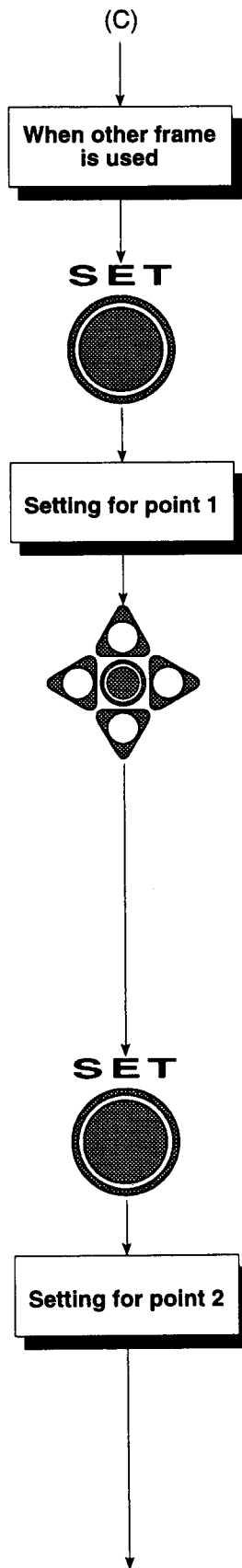

5 F_LIN:3

Press the SET key.

5 FL3 01:

Align a stitch point with a point in the frame by manual frame travel.
(Point 1)

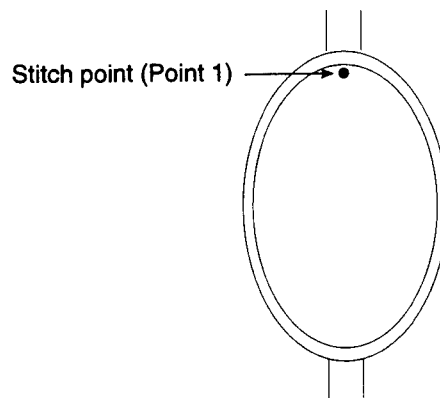

Press the SET key.

5 FL3 02:+ 0 + 0

7. USING THE F1 KEY

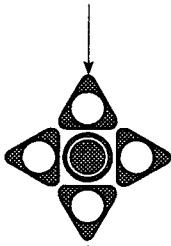

Align another stitch point with a point along the periphery of the frame by manual frame travel. (Point 2)

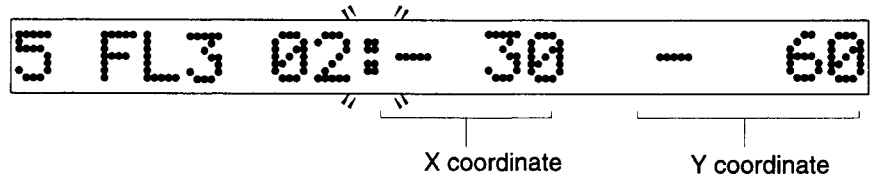
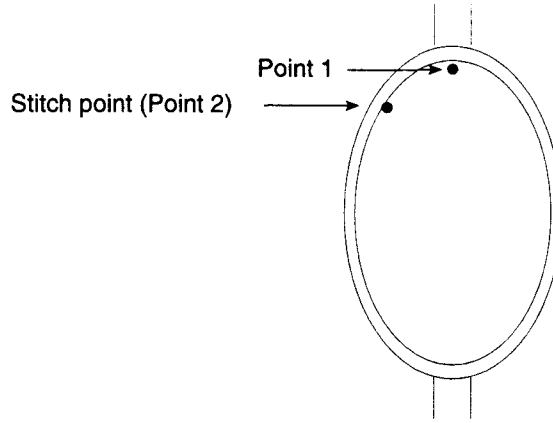

The X-Y coordinates of Point 2 referring to Point 1 (0, 0) are displayed in mm.

Press the SET key.

SET

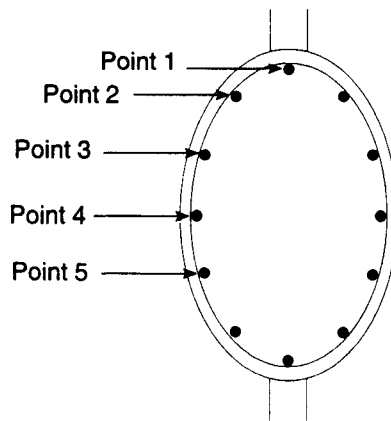
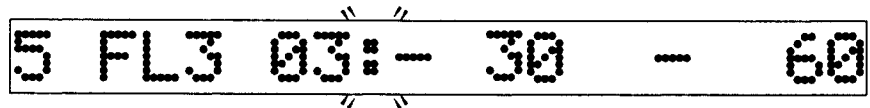
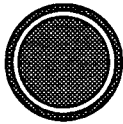

7. USING THE F1 KEY

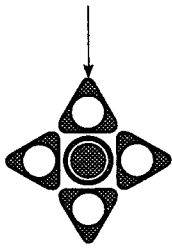



+

SET



SET



Repeat the above procedure by pressing  and  to input other points.

Up to 30 points can be input.

After inputting the last point, press the SET key.

Setting is completed.

* The above setting inputs a software frame shape as follows.

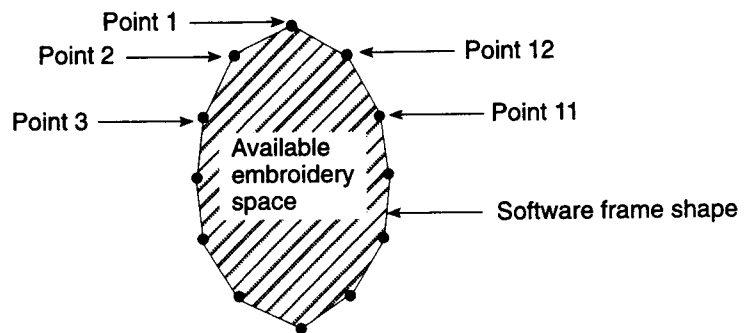

8. USING THE F2 AND F3 KEYS

8. USING THE F2 AND F3 KEYS

8-1 Low Speed RPM

Set the minimum rpm of the machine main shaft.

<Procedure>



Press the F2 key until number **1** is displayed.

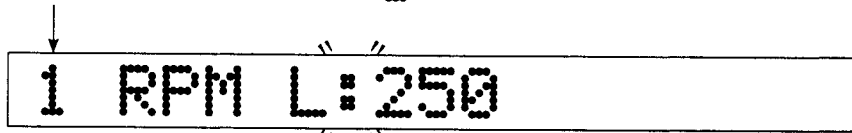

Select an rpm value. (250 to 700)

REMARK: The upper limit of the low speed rpm varies according to the embroidery conditions (types of the frame, thread, etc.).

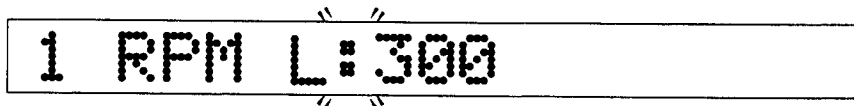

* "300" is selected as an example here.

Press the SET key.

SET



Setting is completed.

8. USING THE F2 AND F3 KEYS

8-2 Number of Start Inching

Setting of the number of times of inching at starting (except starting after manual and automatic trimming)

<Procedure>



Press the F2 key until number 2 is displayed.

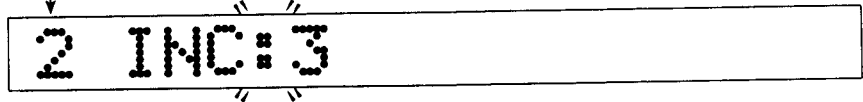

Select the number of times of inching. (0 to 9)

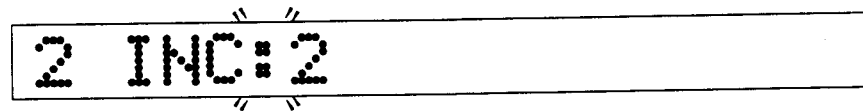

* "2" is selected as an example here.

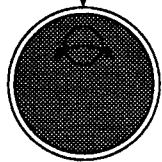

SET

Press the SET key.

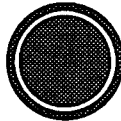

Setting is completed.

8. USING THE F2 AND F3 KEYS

8-3 Frame Travel Speed

Setting of the frame travel speed for origin return, offset travel, etc

<Procedure>



Press the F2 key until number 3 is displayed.

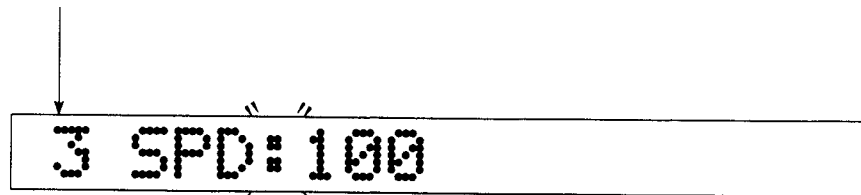

Select a travel speed. [100 (mm/s)
200 (mm/s)



* "200 (mm/s)" is selected as an example here.

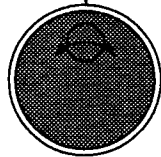

Press the SET key.

SET



Setting is completed.

8. USING THE F2 AND F3 KEYS

8-4 Upper Thread Breakage Detection

Setting of the upper thread breakage detection method

<Procedure>



SET



Press the F2 key until number 4 is displayed.

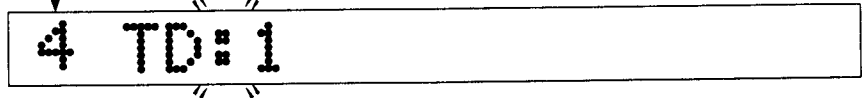

Select:

- : No detection
- 2: Detects twice consecutively
- 1: Detects once

* Select "-" not to execute upper thread breakage.

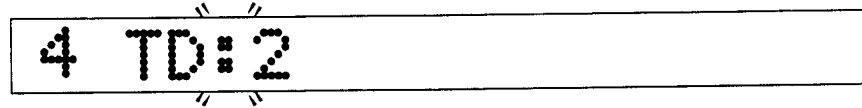

* When "Twice consecutively" is selected.

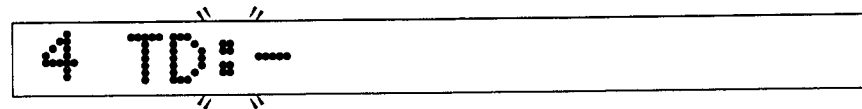

* When "No detection" is selected.

Press the SET key.

Setting is completed.

REMARK: When an upper thread breakage is detected, the "upper thread breakage indicator lamp" (see page 1 – 5) lights in red and the machine stops.

8. USING THE F2 AND F3 KEYS

8-5 ATH (Automatic Thread Trimming)

Setting of 1) ATH operation (automatic thread trimming and holding), 2) thread trimming length, 3) the number of times of inching when started after trimming, and 4) return stitching
 [NOTE 1]

NOTE 1: An operation to prevent mis-stitching when re-started after trimming.

<Procedure>

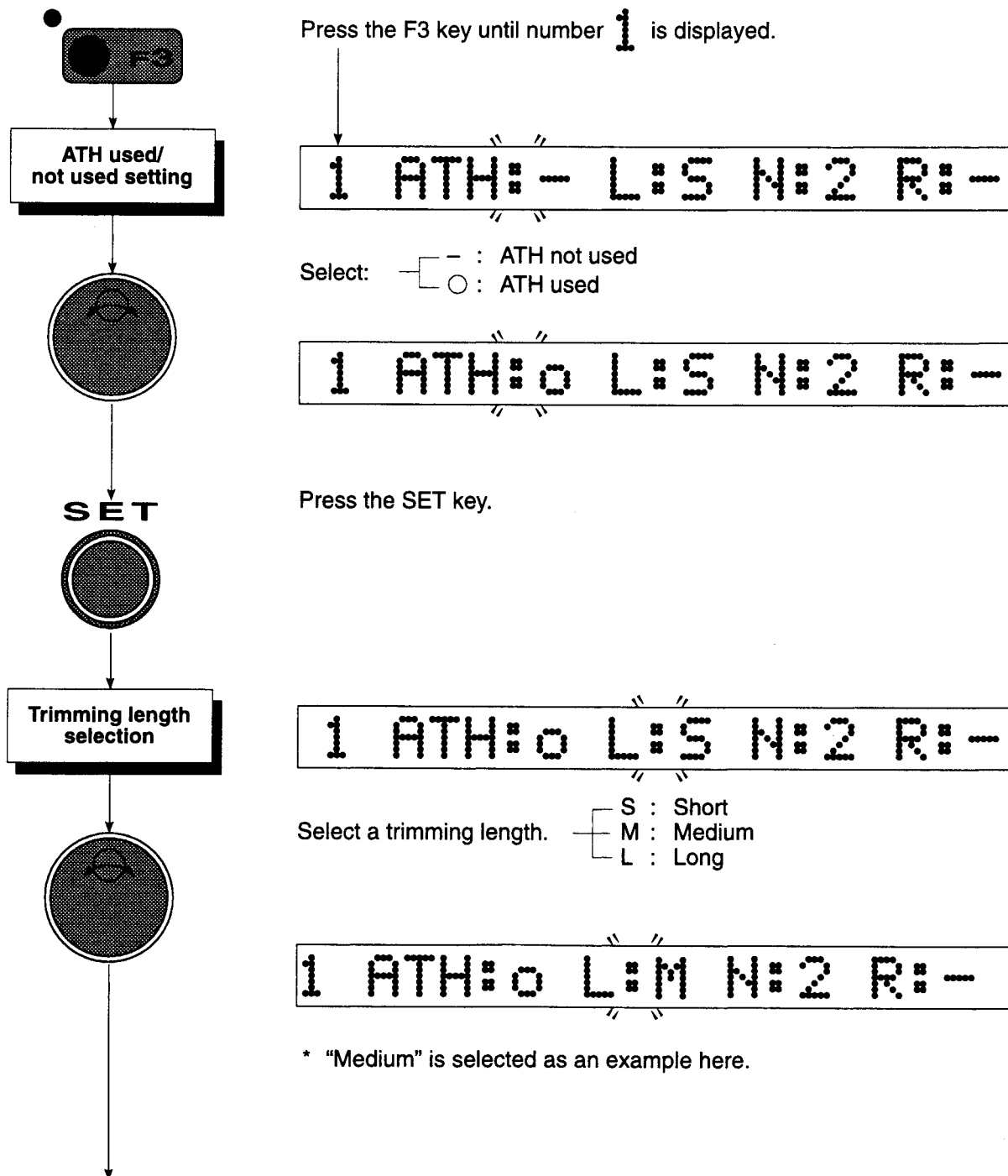

8. USING THE F2 AND F3 KEYS

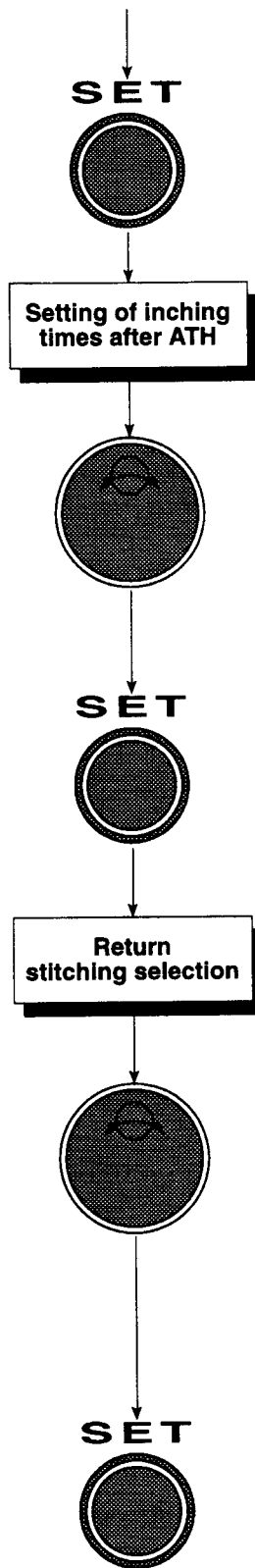

Press the SET key.

1 ATH:0 L:M N:2 R:-

Select the number of times of inching. (2 to 9)

1 ATH:0 L:M N:3 R:-

* "3" is selected as an example here.

Press the SET key.

1 ATH:0 L:M N:3 R:-

Select return stitching Yes/No.
 - : No
 1 : Yes (1 stitch formation)
 2 : Yes (2 stitches formation)

1 ATH:0 L:M N:3 R:2

* "Yes (2 stitches formation)" is selected as an example here.

Press the SET key.

Setting is completed.

8. USING THE F2 AND F3 KEYS

8-6 Max. RPM Limiter

This sets the maximum rpm of the machine main shaft. [NOTE 1, 2]

NOTE 1: The main shaft rpm limit has been set by TAJIMA considering the structure and operability of the machine. Consult your local distributor when changing the maximum rpm limit.

NOTE 2: The value set here is the upper limit of the setting of the "maximum rpm limit" (see page 5 - 1).

<Procedure>

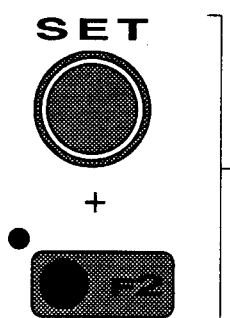

While pressing the SET key, press the F2 key until number **1** is displayed.



Select an rpm value.

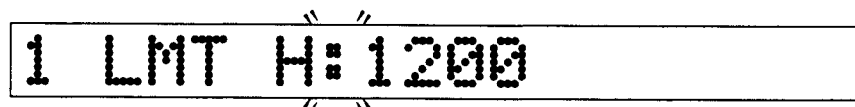

* "1200" is selected as an example here.

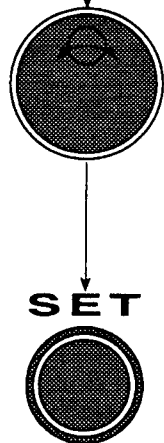

Press the SET key.

Setting is completed.

8. USING THE F2 AND F3 KEYS

8-7 Frame Drive Start Timing

This sets the frame drive start timing. [NOTE 1]

NOTE 1: The frame drive start timing has been set by TAJIMA considering the structure and operability of the machine. Consult your local distributor when changing the maximum rpm limit.

<Procedure>

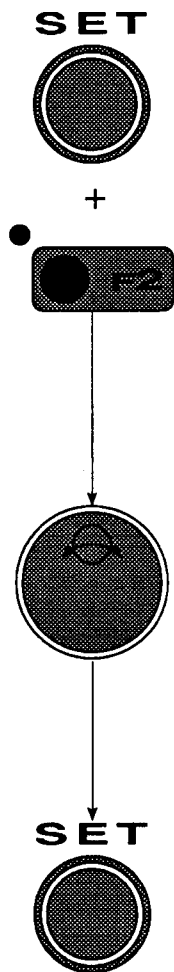

While pressing the SET key, press the F2 key until number 2 is displayed.

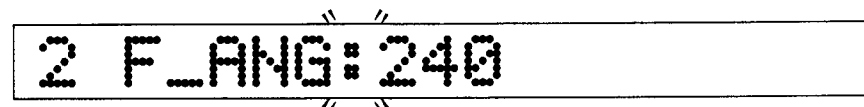

Select a timing. (240° to 270°)

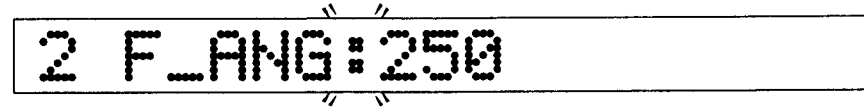

* "250(°)" is selected as an example here.

Press the SET key.

Setting is completed.

8. USING THE F2 AND F3 KEYS

8-8 ATH Timing

This sets the thread trimming motor drive start timing. [NOTE 1]

NOTE 1: The drive start timing has been set by TAJIMA considering the structure and operability of the machine. Consult your local distributor when changing the trimming motor drive start timing.

<Procedure>

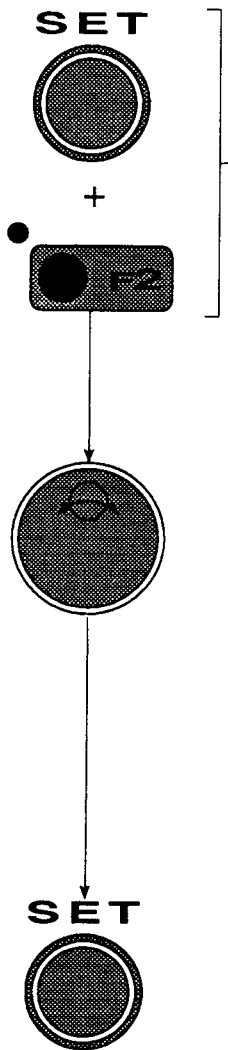

While pressing the SET key, press the F2 key until number **3** is displayed.

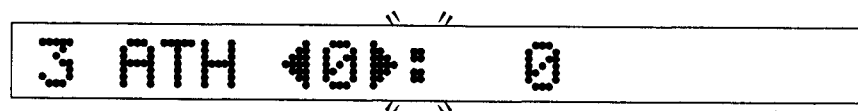

Select the value for adjustment. [NOTE 2] (-10° to 10°)

NOTE 2: Select "delay / advance" value in reference to the basic value of drive start timing.

Example: Selection of "-10" → This sets the largest "advance" value for the drive start timing.

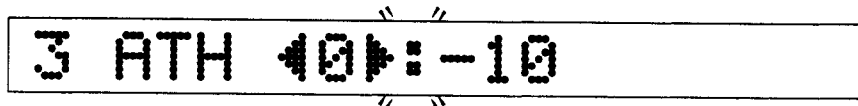

* -10° is selected as an example here.

Press the SET key.

Setting is completed.

9. USING THE DATA EDIT KEY

9. USING THE DATA EDIT KEY

9-1 General Description of Data Editing

Design data stored in the memory can be changed, inserted, or deleted in one-stitch units.

[General flow of editing]

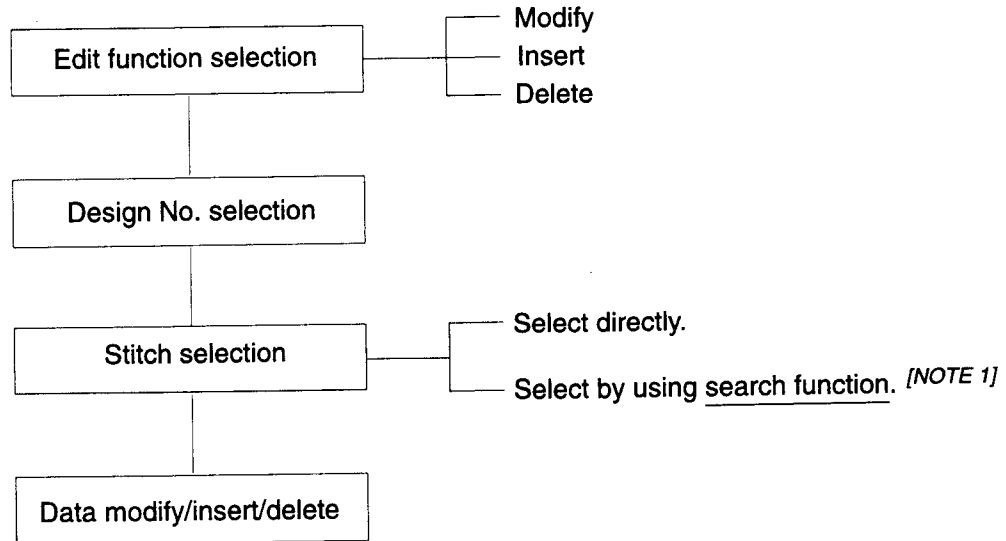

NOTE 1: By designating a function code (stop, jump, sequin, end, ATH, high speed, low speed), stitch data which contains the designated code can be found readily.

REMARK: Data edit during embroidering is possible only with a design which is currently embroidered. Note that the design data of the current and subsequent stitches can only be edited during embroidering.

9. USING THE DATA EDIT KEY

9-2 Data Editing (Modify)

Design data stored in memory can be modified in one-stitch units. A search function can also be used.

<Procedure>



Press the Data edit key until number **1** is displayed.

1 E_MOD

SET

Press the SET key.

Design number selection

1 EM: 1 TAJIMA

* During embroidering, the design number which is currently embroidered is displayed.

Select the design number to be edited.

* During embroidering, other designs cannot be selected.

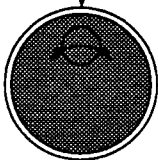

1 EM: 5 SAKURA

* Design number "5" is selected as an example here.

SET

Press the SET key.

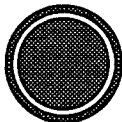

9. USING THE DATA EDIT KEY

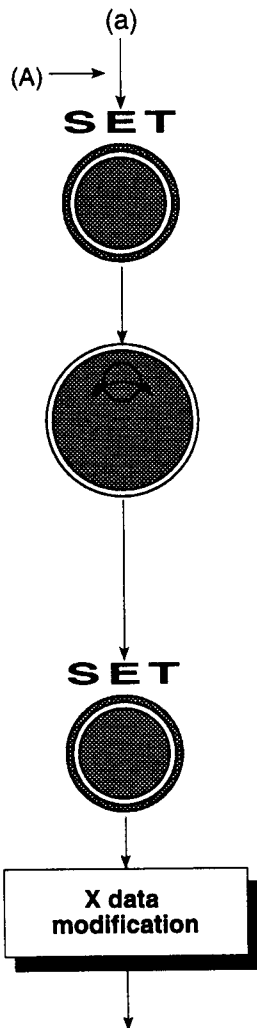
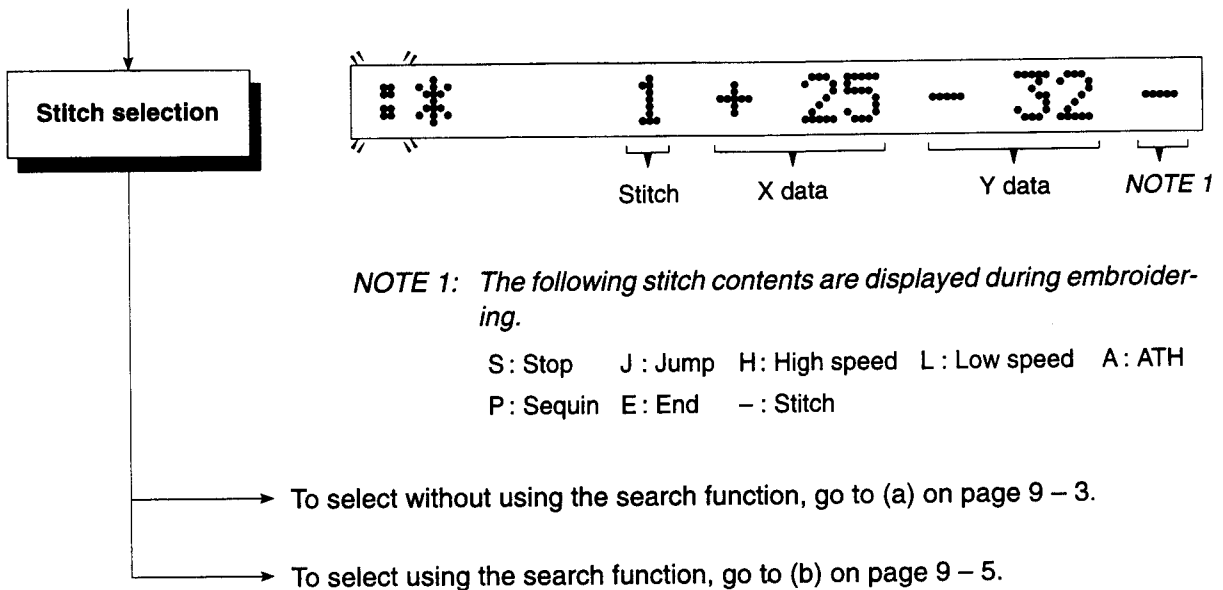

Press the SET key.

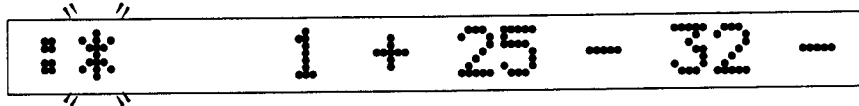

* During embroidering, current stitch data will be displayed.

Select a stitch.

* During embroidering, only the current or subsequent stitches can be selected.

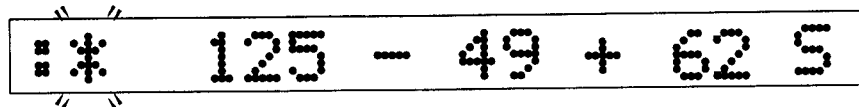

* "125th" stitch is selected as an example here.

Press the SET key.

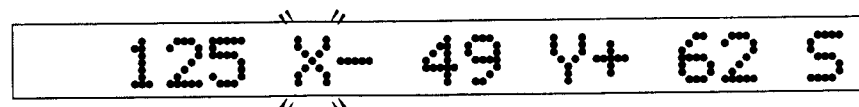

9. USING THE DATA EDIT KEY

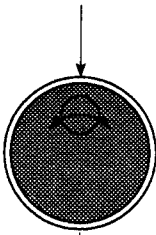

Select the X data modification value.

125 X+ 26 Y+ 62 S

* "+2.6" is selected as an example here.

Press the SET key.

SET

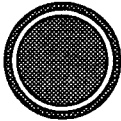

Y data
modification

125 X+ 49 Y+ 62 S

Select the Y data modification value.

125 X+ 26 Y- 39 S

* "-3.9" is selected as an example here.

Press the SET key.

SET

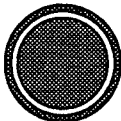

125 X+ 2 Y- 39 S

Select the function code after change.

S : Stop J : Jump H : High speed L : Low speed A : ATH
P : Sequin E : End - : Stitch

125 X+ 2 Y- 39 J

* "Jump" is selected as an example here.

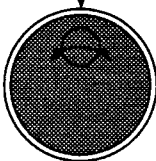

9. USING THE DATA EDIT KEY



Press the SET key.

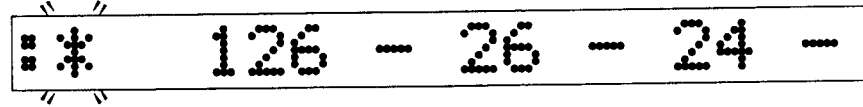

* Stitch number increases.

To change another stitch, go to (A) on page 9 - 3.

To end, press

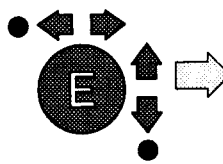

The operation state will switch to "data input is not completed" (see page 2 - 7). Perform "data input" (see page 3 - 1) again.

NOTE 1

NOTE 1: If design data being embroidered have been edited, the operation state will not switch to "data input is not completed", and embroidering can be continued.

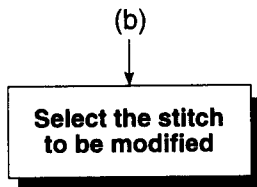

(B)



Select the function code to be searched.

S: Stop J: Jump H: High speed L: Low speed A: ATH
P: Sequin E: End -: Stitch

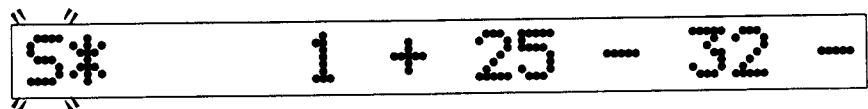

* "Stop" is selected as an example here.

Press the SET key.



The first stitch that contains a stop code is searched.

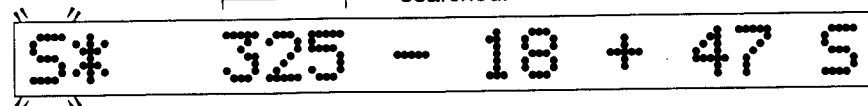

* If a designated function code cannot be found, the display will not change at all.

* Each time the SET key is pressed, the following stitch that contains the same function code is searched.

To continue searching for other function codes, go to (B) above.

9. USING THE DATA EDIT KEY

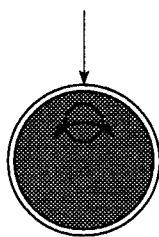

Select "⌘".

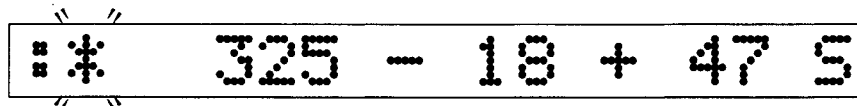

SET

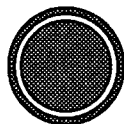

Press the SET key.

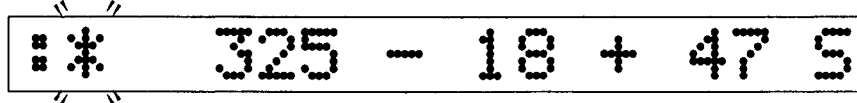

When the searched stitch is the target stitch,

Press the  key and follow the procedure after X data modification (see page 9 - 3).

To increase or decrease from the searched stitch, go to (c) on page 9 - 6.

(c)

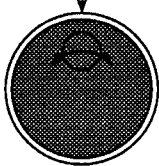

Increase the stitch number.

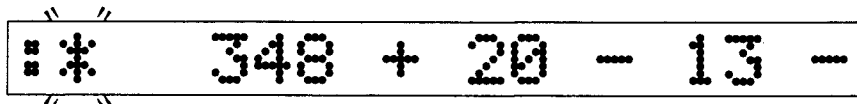

* Stitch number is increased to "348th" stitch as an example here.

SET



Press the SET key.

Continues to X data modification (see page 9 - 3).

9. USING THE DATA EDIT KEY

9-3 Data Editing (Insert)

Other data can be inserted in the design data stored in memory in one-stitch units. A search function can also be used.

<Procedure>

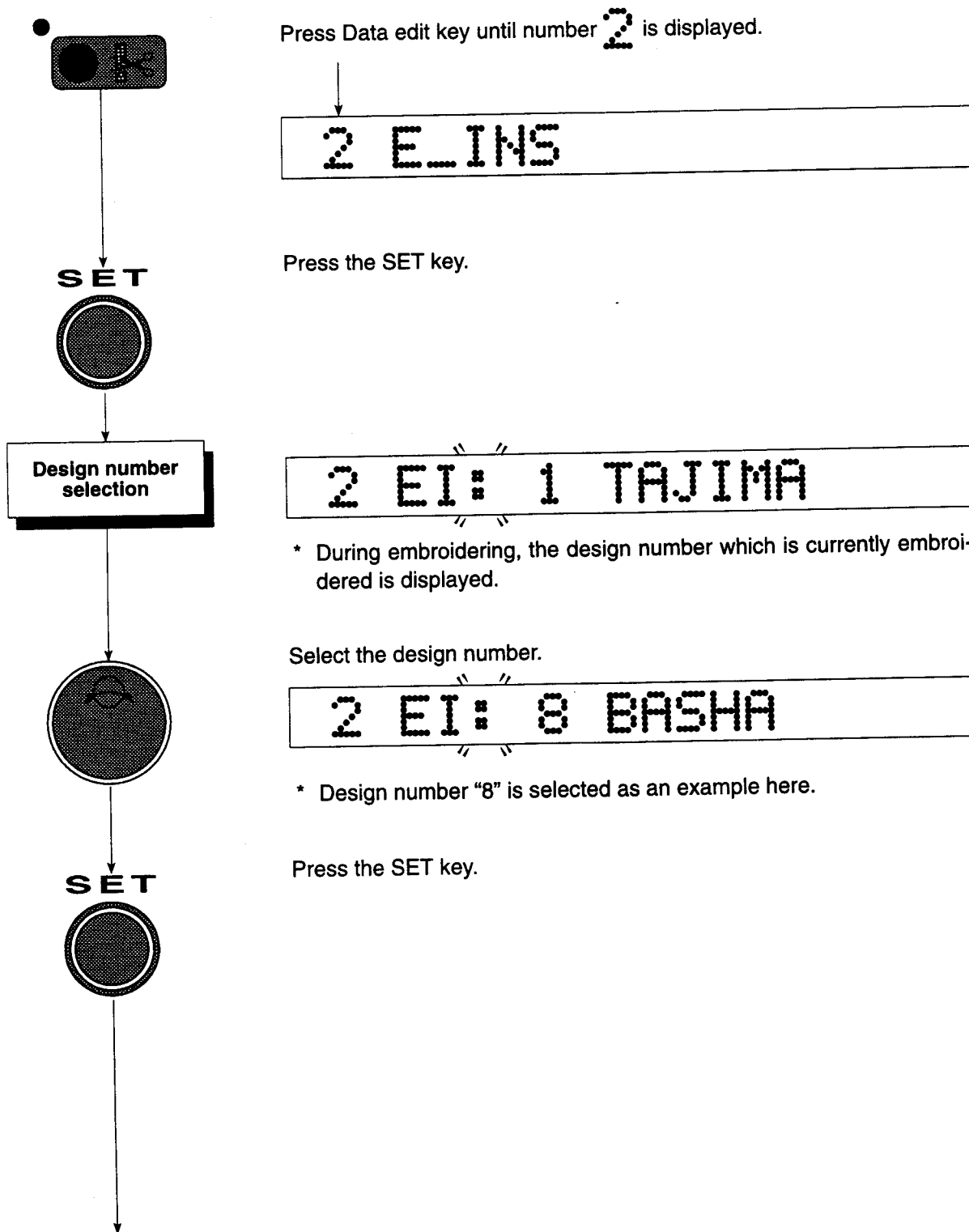

9. USING THE DATA EDIT KEY

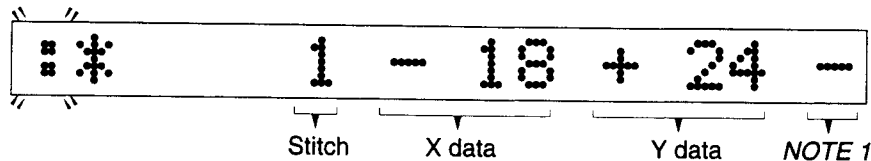
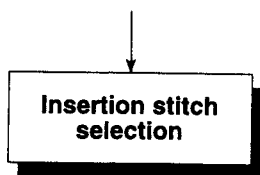

NOTE 1: The following stitch contents are displayed during embroidering.

S: Stop J: Jump H: High speed L: Low speed A: ATH
 P: Sequin E: End -: Stitch

- To select without using the search function, go to (a) on page 9 – 8.
- To select using the search function, go to (b) on page 9 – 11.

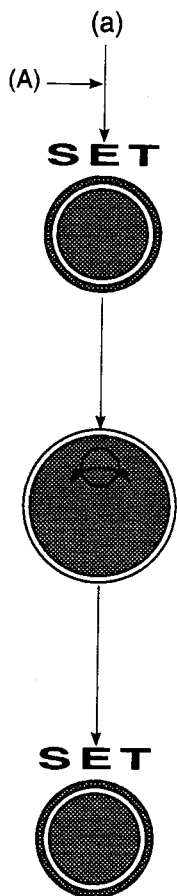

Press the SET key.

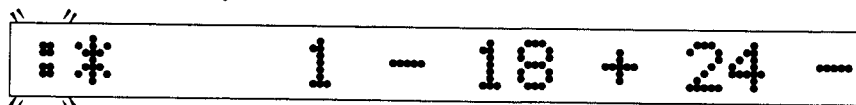

Select the stitch.

* During embroidering, only the current or subsequent stitches can be selected.

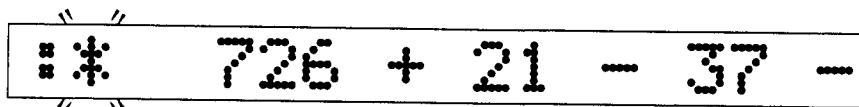

* The "726th" stitch is selected as an example here.

Press the SET key.

9. USING THE DATA EDIT KEY

X data insertion

726 X 0 Y 0 -

Select the X data to be inserted.

726 X+ 15 Y 0 -

* "+1.5" is selected as an example here.

Press the SET key.

SET

Y data insertion

726 X+ 15 Y 0 -

Select the Y data to be inserted.

726 X+ 15 Y- 12 -

* "-1.2" is selected as an example here.

Press the SET key.

SET

Function data insertion

726 X+ 15 Y- 12 -

9. USING THE DATA EDIT KEY

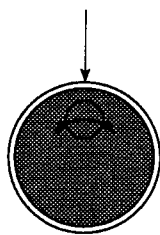

Select the function data to be inserted.

S : Stop J : Jump H : High speed L : Low speed A : ATH
 P : Sequin E : End - : Stitch

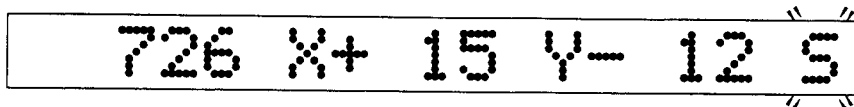

* "Stop" is selected as an example here.

SET

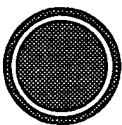

Press the SET key.

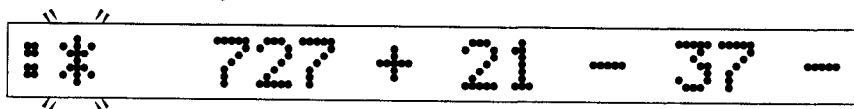

* Stitch number increases and the contents of the 726th stitch will be displayed.

To change another stitch, go to (A) on page 9 – 8.

To end, press

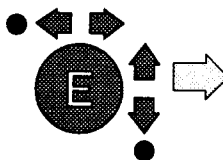

The operation state will switch to "data input is not completed" (see page 2 – 7). Perform "data input" (see page 3 – 1) again.

NOTE 1

NOTE 1: If design data being embroidered have been edited, the operation state will not switch to "data input is not completed", and embroidering can be continued.

9. USING THE DATA EDIT KEY

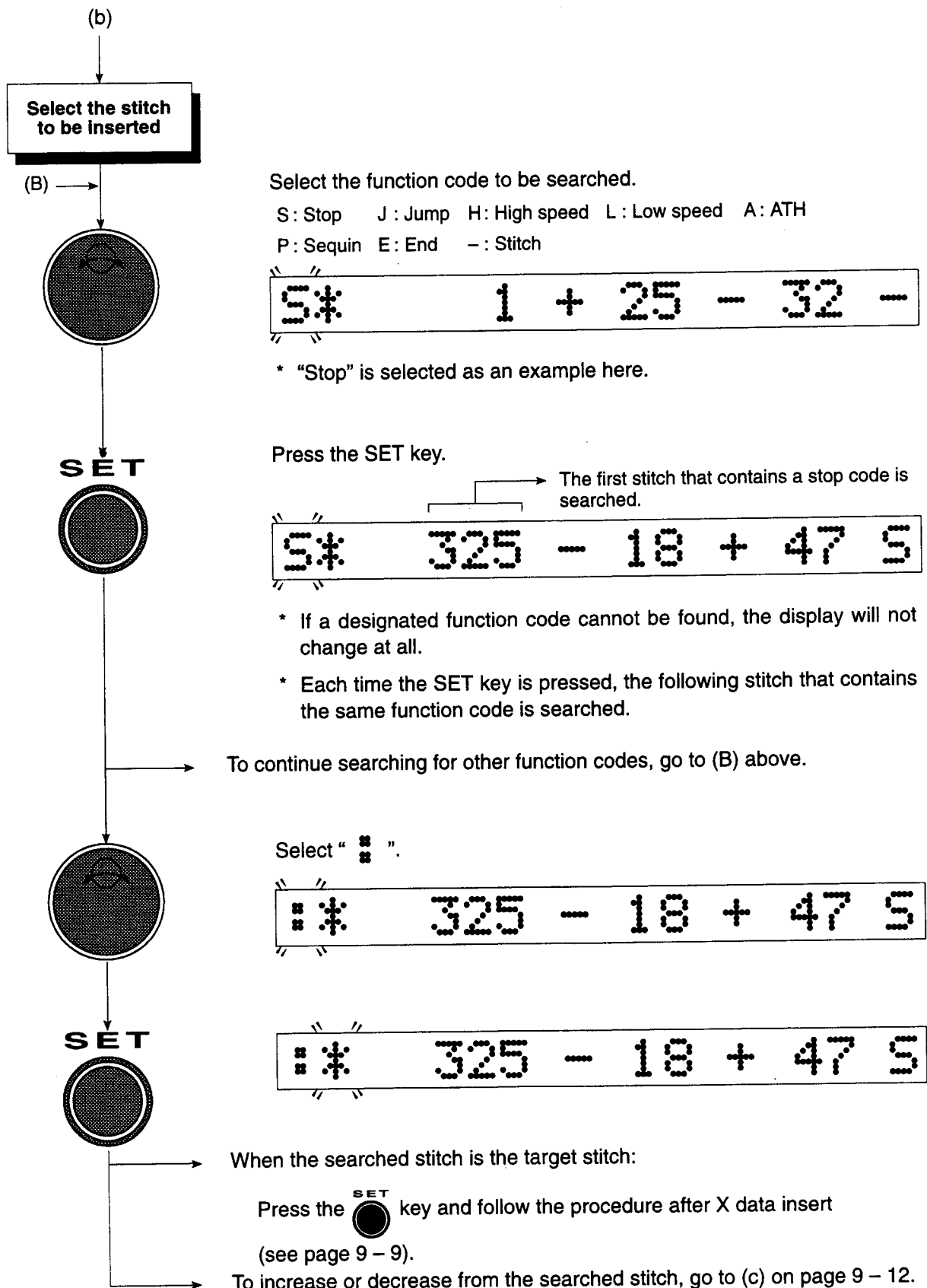

9. USING THE DATA EDIT KEY

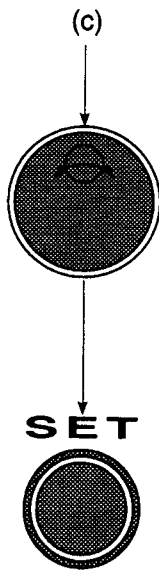

Increase the stitch number.

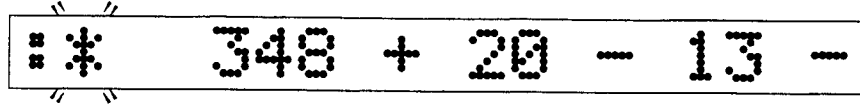

* Stitch number is increased to "348th" stitch as an example here.

Press the SET key.

Continues to X data insert (see page 9 - 9).

9. USING THE DATA EDIT KEY

9-4 Data Editing (Delete)

Design data stored in memory can be deleted in one-stitch units. A search function can also be used.

<Procedure>

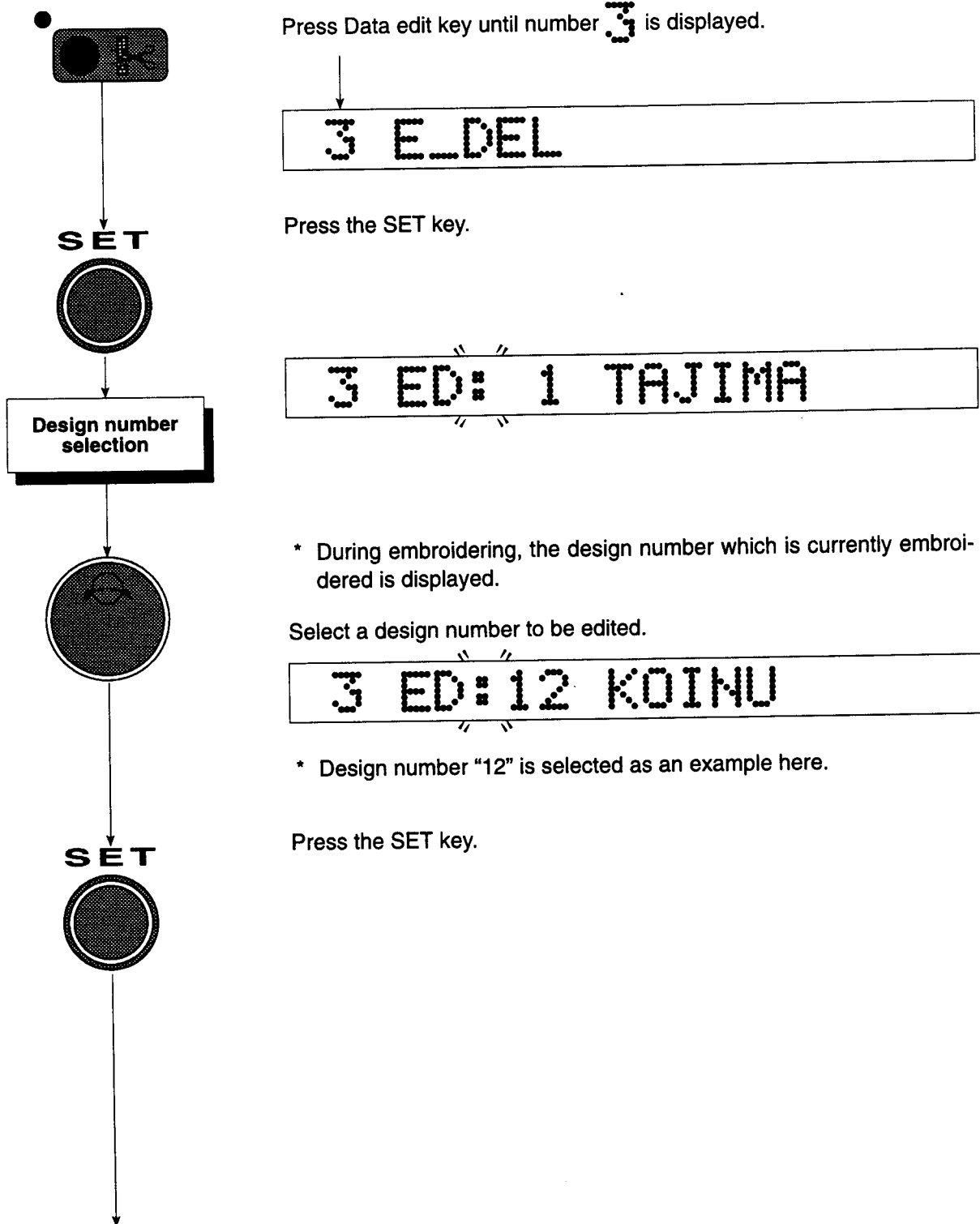

9. USING THE DATA EDIT KEY

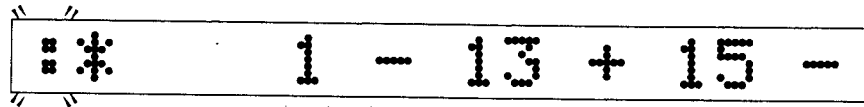
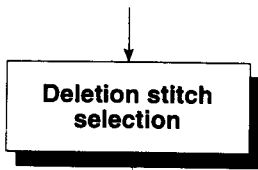

NOTE 1: The following stitch contents are displayed during embroidering.

S: Stop J: Jump H: High speed L: Low speed A: ATH
 P: Sequin E: End -: Stitch

- To select without using the search function, go to (a) on page 9 – 14.
- To select using the search function, go to (b) on page 9 – 16.

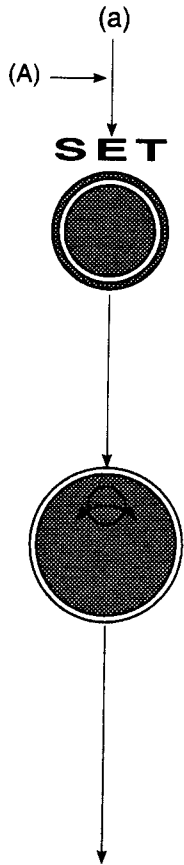

Press the SET key.

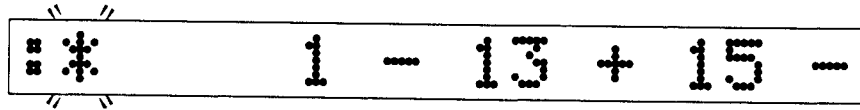

Select the stitch.

* During embroidering, only the current or subsequent stitches can be selected.

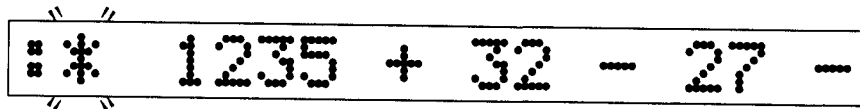

* "1235th" stitch is selected as an example here.

9. USING THE DATA EDIT KEY



Press the SET key.

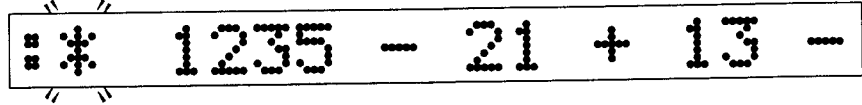

The "1235th" stitch data is deleted.

* After stitch data is deleted, stitch data of the original "1236th" stitch is displayed.

(C)

To delete another stitch, return to (A) above.

To end, press

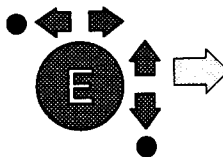

The operation state will switch to "data input is not completed" (see page 2 - 7). Perform "data input" (see page 3 - 1) again.

NOTE 1

NOTE 1: If design data being embroidered have been edited, the operation state will not switch to "data input is not completed", and embroidering can be continued.

9. USING THE DATA EDIT KEY

(b)
 Select the stitch to be deleted

(B) →



Select the function code to be searched.

S : Stop J : Jump H : High speed L : Low speed A : ATH
 P : Sequin E : End - : Stitch

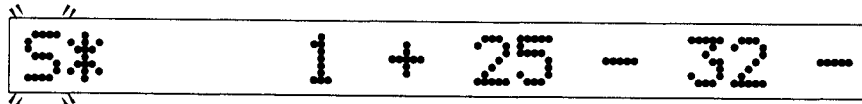

* "Stop" is selected as an example here.

Press the SET key.

SET

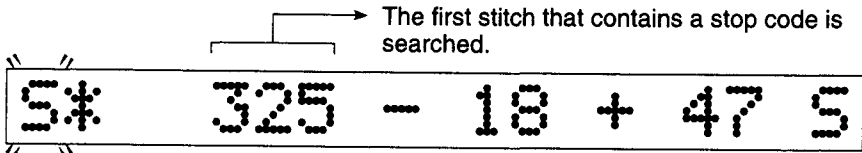
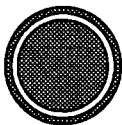

* If a designated function code cannot be found, the display will not change at all.

* Each time the SET key is pressed, the following stitch that contains the same function code is searched.

To continue searching for other function codes, go to (B) above.

Select "■".

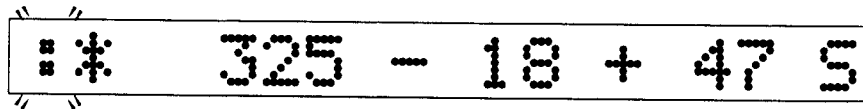
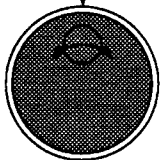

Press the SET key.

SET

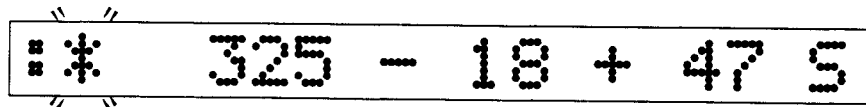
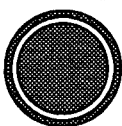

When the searched stitch is the target stitch,

Press the  key to delete the stitch.

Go to (C) on page 9 - 15.

To increase or decrease from the searched stitch, go to (c) on the next page.

9. USING THE DATA EDIT KEY

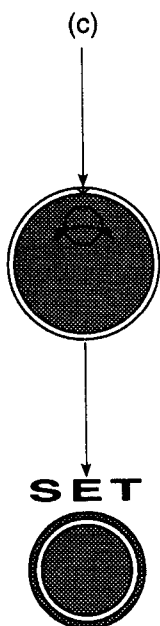

⌘* 325 - 18 + 47 5

Increase the stitch number.

⌘* 348 + 20 - 13 -

* Stitch number is increased to the "348th" stitch as an example here.

Press the SET key. → Data of the "348th" stitch is deleted.

⌘* 348 - 63 + 27 -

* The next stitch data is displayed.

* The contents of the 349th stitch will be displayed as that for the 348th stitch.

Go to (C) on page 9 - 15.

10. USING THE FLOPPY PROCESS KEY

10. USING THE FLOPPY PROCESS KEY

10-1 Floppy Disk Processing

The following operations can be executed by using the built-in FDD:



CAUTION

If the power supply is turned OFF or a power failure occurs during operation 1, 2, or 3 mentioned below, part or all of design data on the floppy disk may be damaged.

If a floppy disk in which design data have been stored is initialized, all design data in the disk will be lost.

(1) Write

Design data stored in the memory can be written to a floppy disk. → page 10 – 2

(2) Delete

Design data on a floppy disk can be deleted in 1-design units. → page 10 – 5

(3) Initialize

Floppy disks can be initialized *[NOTE]*. → page 10 – 6

NOTE: This operation is used to format a floppy disk so that it can be used with this machine. TAJIMA brand floppy disks can be used without this process since they are supplied as initialized.

10. USING THE FLOPPY PROCESS KEY

10-2 Floppy Disk Processing (Write)

Writes design data stored in memory to a floppy disk.

<Procedure>

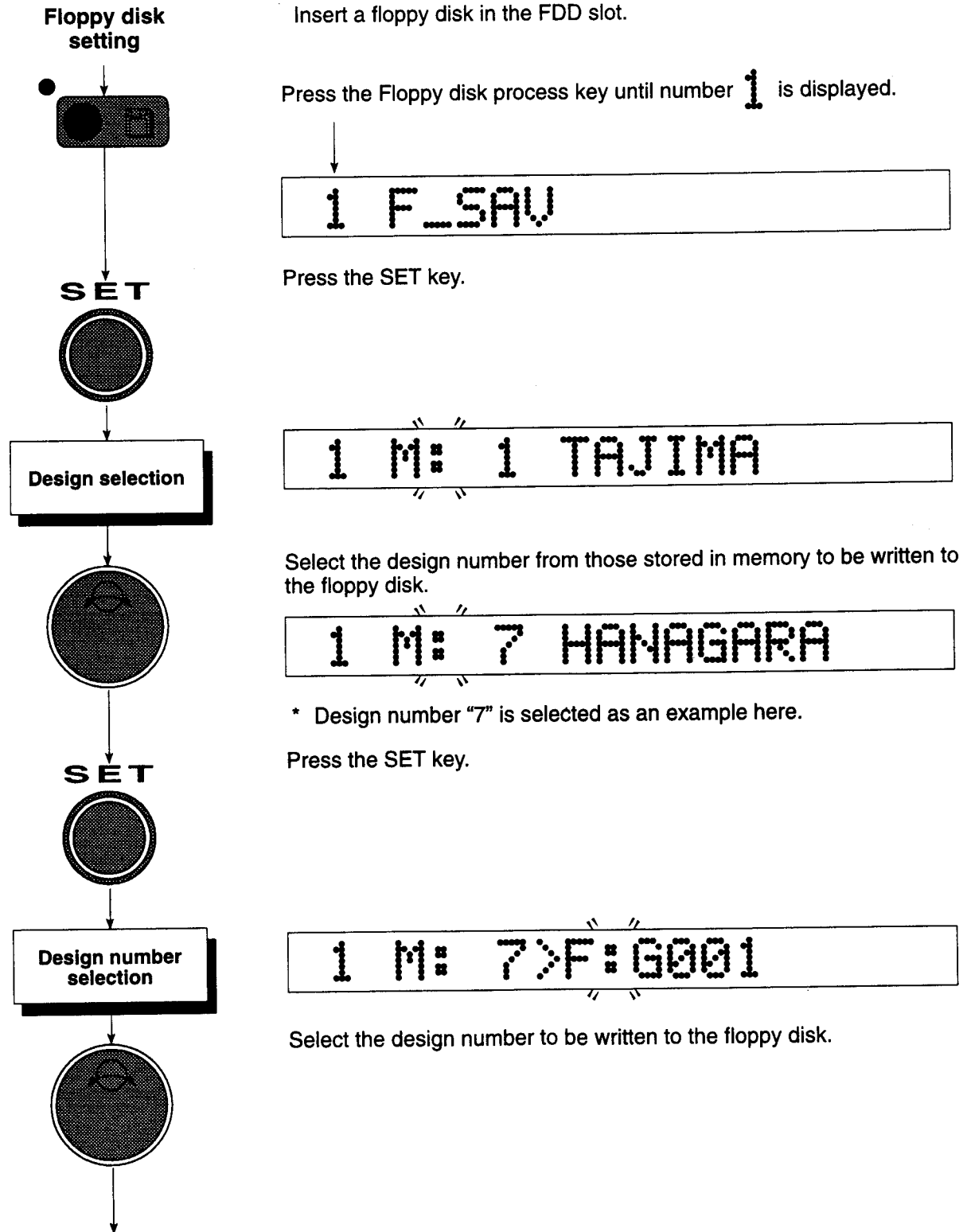

10. USING THE FLOPPY PROCESS KEY

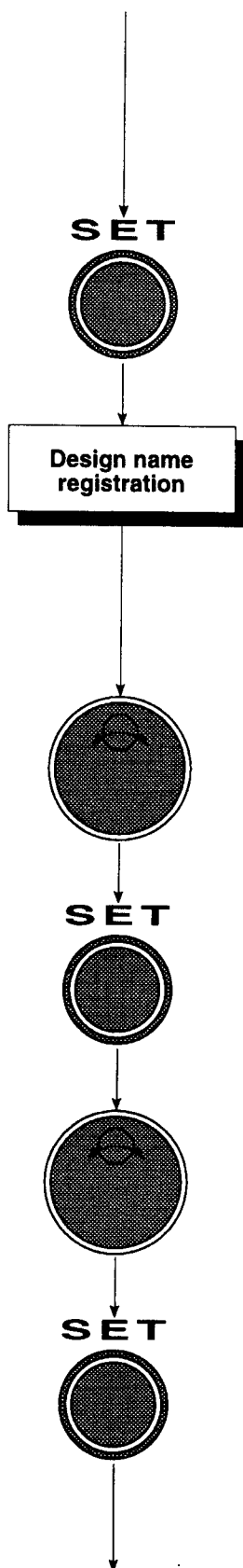

1 M: 7>F:G003

* Design number "3" is selected as an example here.

Press the SET key.

1 M 7>G001: -

Select a character (up to eight characters from 0 to 9, and A to Z).

* The following procedure is an example for when a design name "INU" is to be registered.

Select "I".

1 M 7>G001: I

Press the SET key.

1 M 7>G001: I-

Select "N".

1 M 7>G001: IN

Press the SET key.

10. USING THE FLOPPY PROCESS KEY

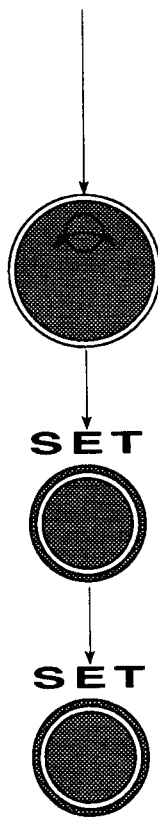

1 M 7>G001: IN-

Select "U".

1 M 7>G001: INU

Press the SET key.

1 M 7>G001: INU-

Press the SET key.

1 M 7>G001: INU

This flashes while writing. [NOTE 1]

Setting is completed.

NOTE 1: All operations are disabled while this is flashing (writing). Operation is allowed when this changes to steadily light.

10. USING THE FLOPPY PROCESS KEY

10-3 Floppy Disk Processing (Delete)

Deletes design data in one-design units stored in floppy disk.

<Procedure>

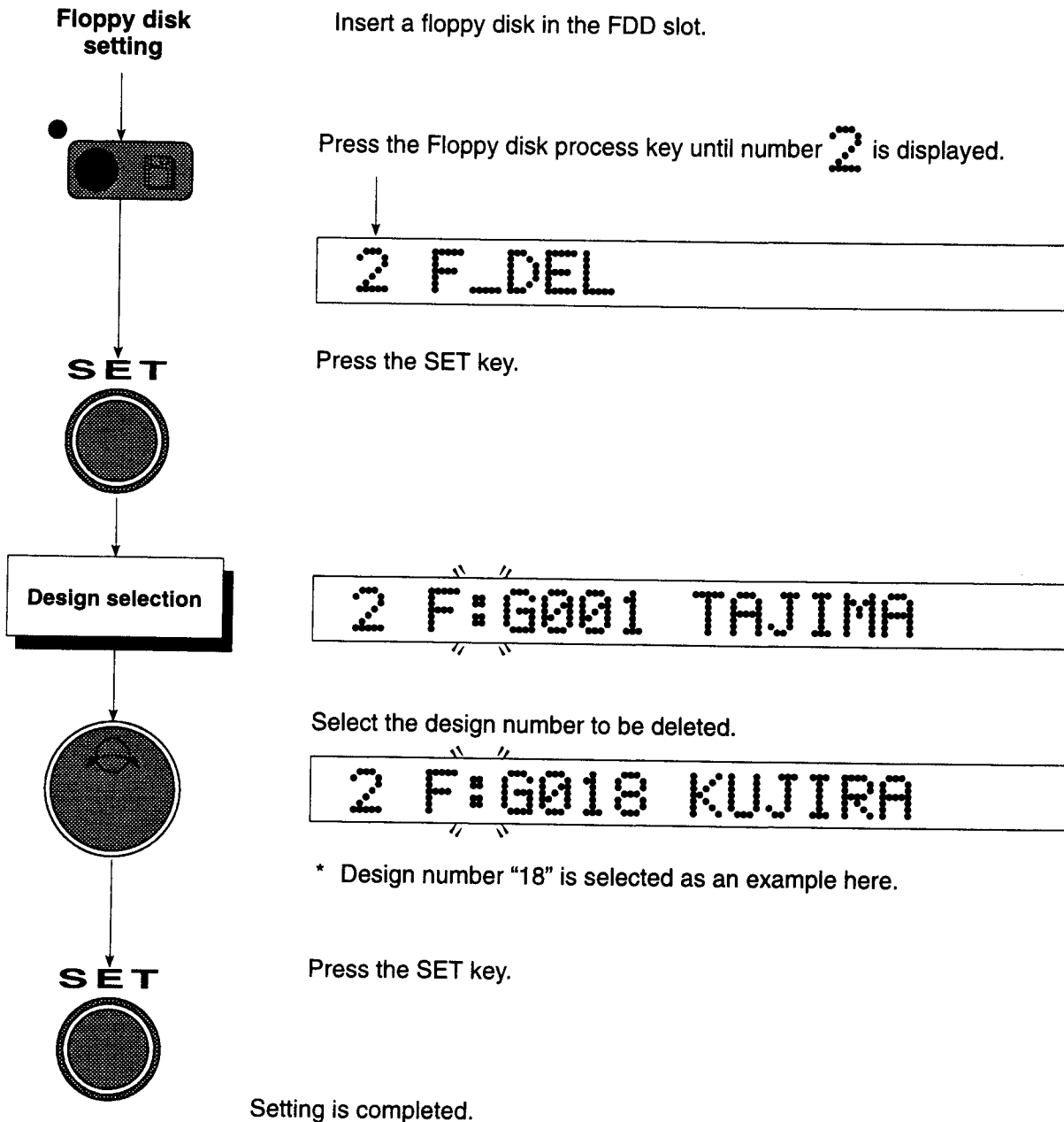

10. USING THE FLOPPY PROCESS KEY

10-4 Floppy Disk Processing (Initialize)

Initializes a floppy disk so that it is used with the machine.



CAUTION

Floppy disks other than the TAJIMA brand can be used with the machine after they are initialized as given above. However, TAJIMA does not warrant the quality of data written to such the floppy disks.

If a floppy disk in which design data have been stored is initialized, all design data in the disk will be lost.

<Procedure>

Floppy disk setting

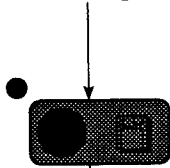

Insert a floppy disk in the FDD slot.

Press Floppy disk process key until number 3 is displayed.

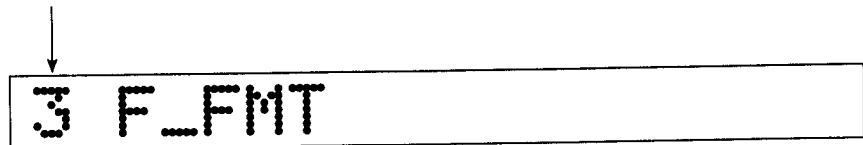

Press the SET key.

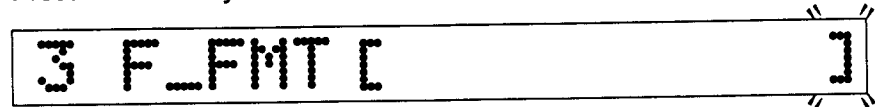

* An alert is given by buzzer sound.

Press the SET key.



Setting is completed.



* The > symbol moves to the right as processing progresses. Processing is completed when the symbol reaches the right side bracket.

11. CONFIRMATION MODE

11. CONFIRMATION MODE

11-1 General Description

This mode allows to confirm the contents of current settings without making modification.

■ Switching to the confirmation mode

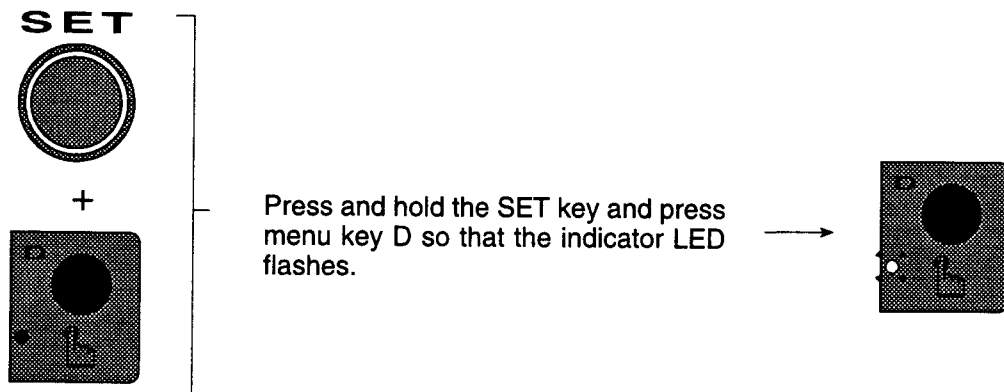

REMARK 1: Switching to the confirmation mode is possible only in the “normal display” state (see page 2 – 7).

REMARK 2: The confirmation operations after switching to the confirmation mode are the same as standard setting operations except that for “data input”, “direct data input”, “needle bar selection”, and “software frame limit” (see page 11 – 2 to 11 – 7).

■ Canceling the confirmation mode

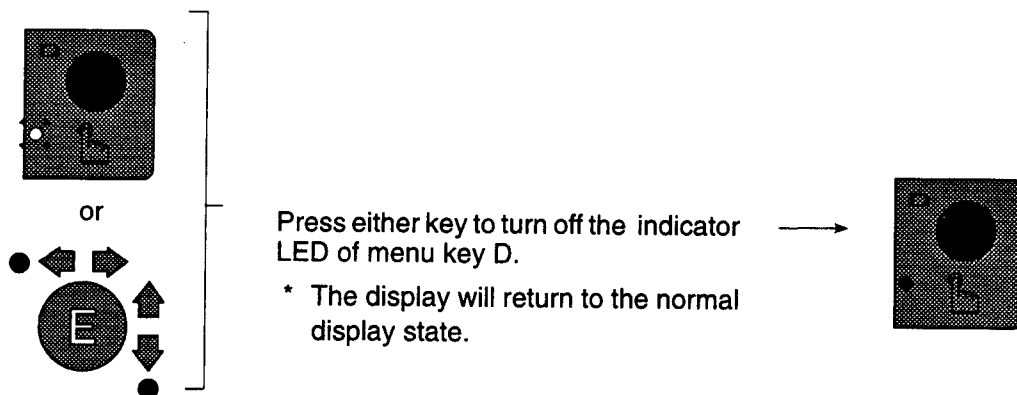

REMARK: Pressing the START key also cancels the confirmation mode. Use caution because the machine will start operation immediately when the START key is pressed.

11. CONFIRMATION MODE

11-2 Example of Confirmation Operation

Press the key that corresponds to the item to be confirmed until a specific item is displayed.

- Confirming input state (data input, direct data input)

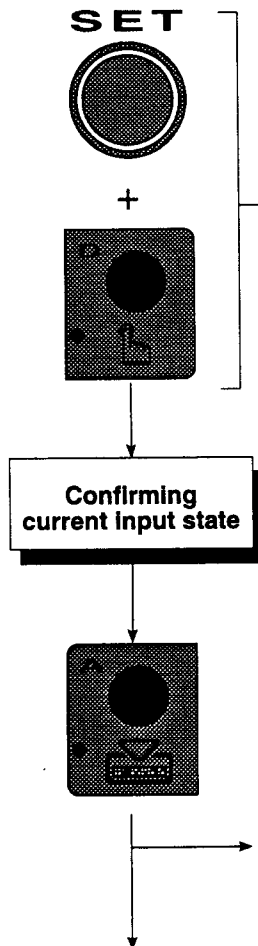

Press and hold the SET key and press menu key D so that the indicator LED flashes.

One of the following screen will be displayed.

Data input (memory operation state)

M: 3 CARRIAGE 32514

Design number

Design name (up to 8 characters)

Number of stitches of the design (up to 6 digits)

11. CONFIRMATION MODE

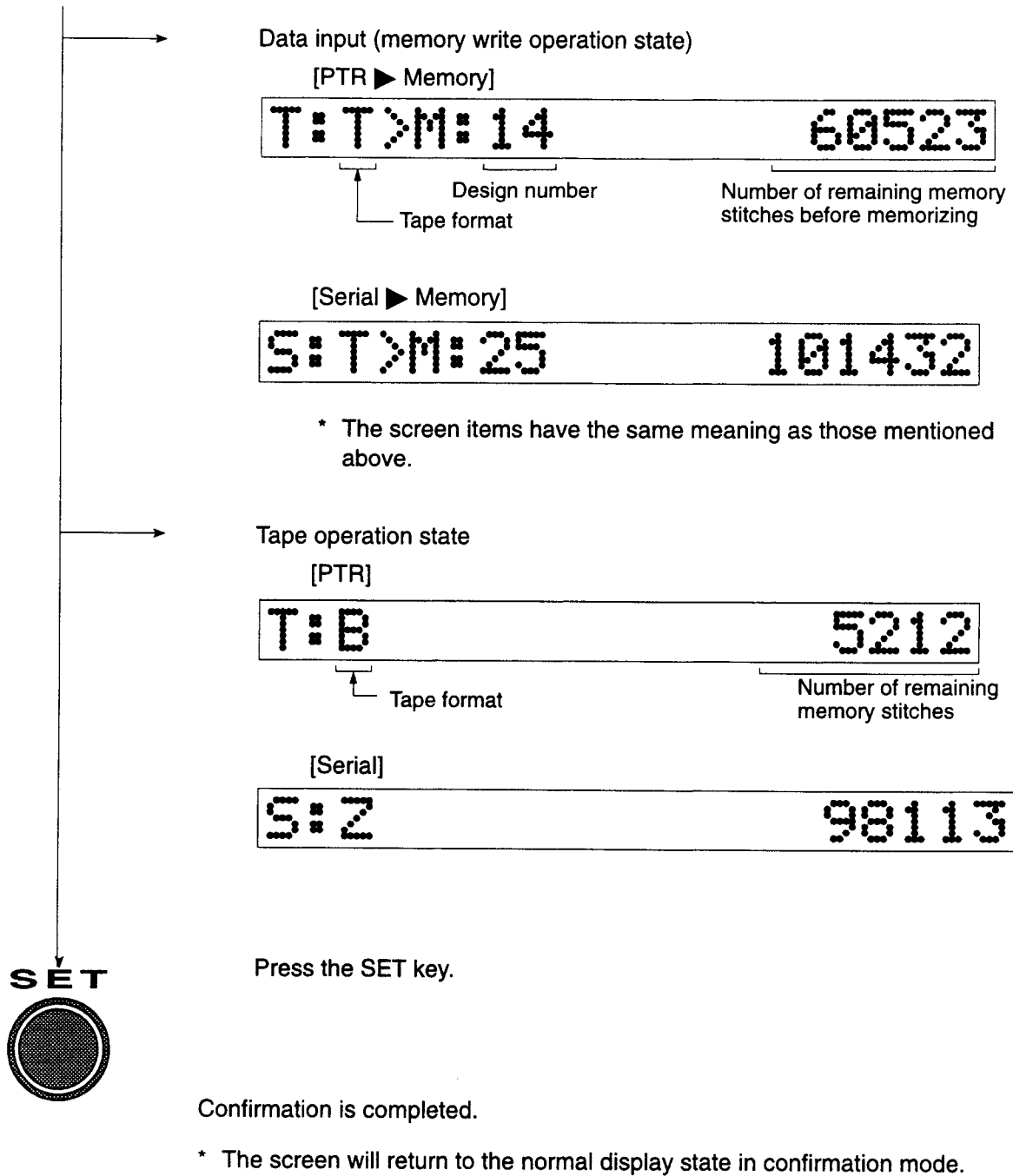

REMARK: To cancel the confirmation mode, follow the procedure for canceling the confirmation mode given on page 11 - 1.

11. CONFIRMATION MODE

■ Confirming the needle bar selection

Example:

When needle No. 2 which is the third step of 12 preset steps 3, 6, 2, 1, 5, 7, 9, 8, 4, 1, 5, and 7 is currently selected

REMARK: Needle bar numbers 10 and larger are displayed as follows.

10 → a, 11 → b, 12 → c

<Procedure>

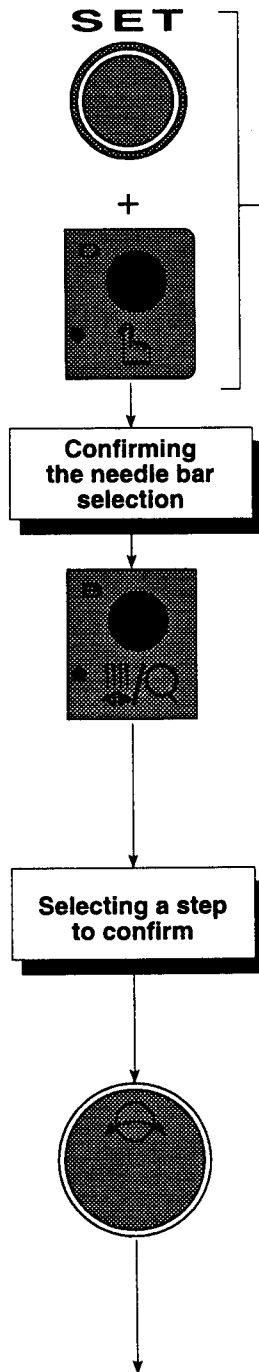

Press and hold the SET key and press menu key D so that the indicator LED flashes.

Press the key until number **2** is displayed.

2 NDL(03): 3621579841

* Number "2" of the third step will flash.

REMARK: While in confirmation mode, the needle bar selection setting can be confirmed even when "manual color change" has been selected.

Turn the jog dial (inside) and select a step number (flashing).

2 NDL(01): 3621579841

11. CONFIRMATION MODE

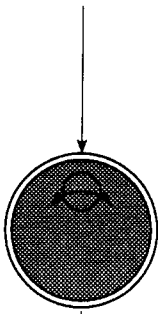

- * Turning the dial counterclockwise moves the flashing digit to the left. The flashing digit does not move to the left over the first step.

2 NDL(10): 3621579841

- * Turning the dial clockwise moves the flashing digit to the right.

Turn it clockwise further.

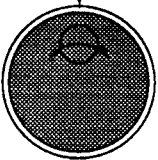

2 NDL(11): 6215798415

- * The 11th step will flash.

Turn it clockwise further.



2 NDL(12): 2157984157

- * The flashing digit does not move to the right over the 12th step.

SET

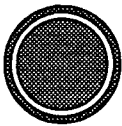

Press the SET key.

Confirmation is completed.

- * The screen will return to the normal display state in confirmation mode.

REMARK: To cancel the confirmation mode, follow the procedure for canceling the confirmation mode given on page 11 – 1.

11. CONFIRMATION MODE

■ Confirming the software frame limit

<Procedure>

SET



+

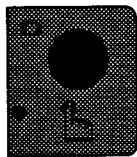

SET

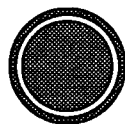

Press and hold the SET key and press menu key D so that the indicator LED flashes.

Press the key until number 5 is displayed.

5 FL2 01: + 0 + 0

X coordinate Y coordinate

Point number : Point number 1 will be displayed on the first screen.

Frame shape { FL1 : Square frame
FL2 : Round frame
FL3 : Other shape

* Screen when the software frame limit has not been set.

5 F_LIM: -

Press the SET key.

5 FL2 02: +144 - 250

* The set values (X-Y coordinates) of point number 2 will be displayed.

* The point number indication increases as the SET key is pressed and the set values for selected point number will be displayed. Pressing the SET key when the last point number and the set values are displayed will return the screen to the normal display state. The confirmation mode will not be canceled.

REMARK: To cancel the confirmation mode, follow the procedure for canceling the confirmation mode given on page 11 - 1.

11. CONFIRMATION MODE

■ Confirming the data conversion

<Procedure>

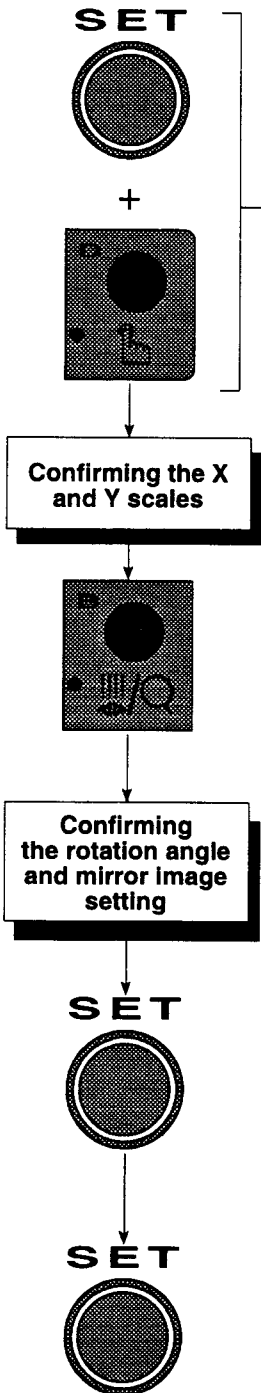

Press and hold the SET key and press menu key D so that the indicator LED flashes.

Press the key until number 3 is displayed.

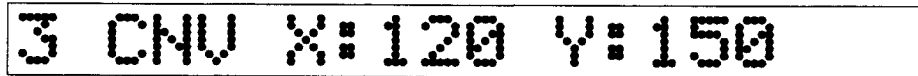

* The X and Y scales will be displayed.

Press the SET key.

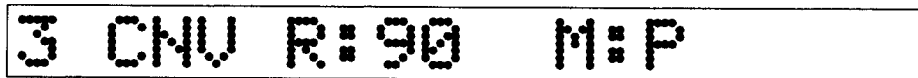

* The rotation angle and mirror image setting (yes/no) will be displayed.

Press the SET key.

Confirmation is completed.

* The screen will return to the normal display state in confirmation mode.

REMARK: To cancel the confirmation mode, follow the procedure for canceling the confirmation mode given on page 11 - 1.

11. CONFIRMATION MODE

■ Confirming the automatic offset

<Procedure>

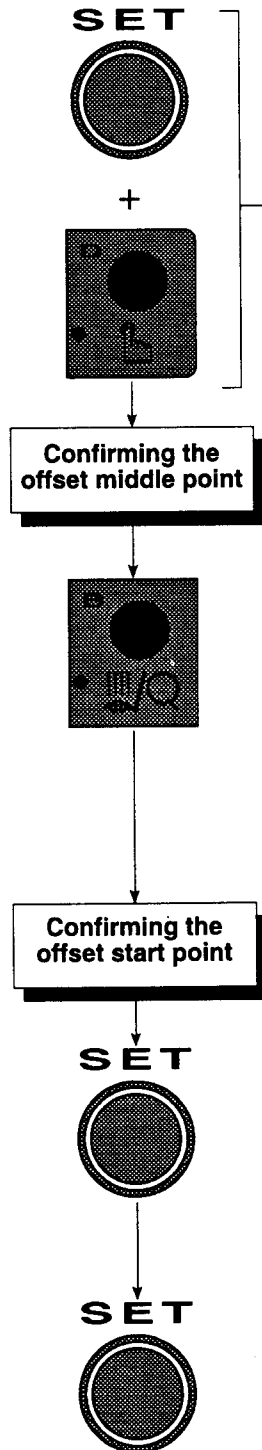

Press and hold the SET key and press menu key D so that the indicator LED flashes.

Press the key until number **5** is displayed.

5 OF1 X: +370 Y: +291

* The offset middle point (OF1) will be displayed with X and Y coordinate values.

Confirming the offset start point

Press the SET key.

5 OF2 X: +540 Y: +169

* The offset start point (OF2) will be displayed with X and Y coordinate values.

Press the SET key.

Confirmation is completed.

* The screen will return to the normal display state in confirmation mode.

REMARK: To cancel the confirmation mode, follow the procedure for canceling the confirmation mode given on page 11 - 1.

12. USING THE F3 AND F4 KEYS

12. USING THE F3 AND F4 KEYS

12-1 OPTIONAL DEVICES

The optional devices which can be used with this machine and required settings are described below.

(1) UTC (Under thread breakage detection)

Set whether or not under thread breakage is detected. → page 12 – 2

(2) BOR (Boring)

Set whether or not boring is performed and set the data processing method for boring. → page 12 – 3

(3) COD (Code)

Set whether or not cording is performed. → page 12 – 4

(4) Network connection

Set whether or not NW-II (Tajima Two-Way Network System) is connected.
→ page 12 – 5

12. USING THE F3 AND F4 KEYS

12-2 UTC (Under Thread Breakage Detection)

Set whether or not under thread breakage detection is executed for the FX head.

<Procedure>



Press the F3 key until number 2 is displayed.

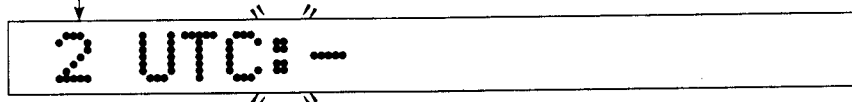

Select: —: Thread breakage detection is not set.
4: Thread breakage detection is set.
(4 consecutive stitches)
5: Thread breakage detection is set.
(5 consecutive stitches)

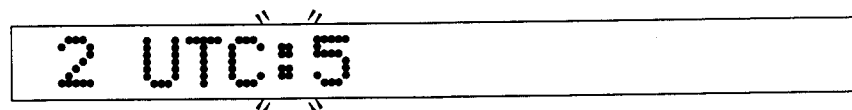

* "Detection for 5 consecutive stitches" is set as an example here.

SET

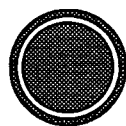

Press the SET key.

Setting is completed.

REMARK: When an under thread breakage is detected, the error code [291] (see page 13 - 1) will be displayed and the machine will stop.

12. USING THE F3 AND F4 KEYS

12-3 BOR (Boring)

Set whether or not boring is executed and the method of data processing for boring.

<Procedure>

REMARK: Setting for boring cannot be made during embroidering.

Press the F3 key until number 3 is displayed.

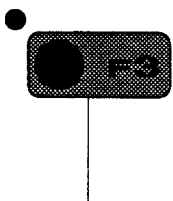

3 BOR: -

Select whether or not boring is executed and the method of data processing.

- : Boring is not done.
- 1 : Boring is done. Data is not processed.
(Frame output is done according to data.)
- 2 : Boring is done. Offset amount of data is erased and mechanical offset is added 12 mm.
(Data conversion enabled)
- 3 : Boring is done. Mechanical offset amount is added 12 mm. (Data conversion is enabled)

REMARK 1: When a tape contains boring offset data, select Step 1 (data conversion disabled) or Step 2 (data conversion enabled).

REMARK 2: When a tape does not contain boring offset data, select Step 3.

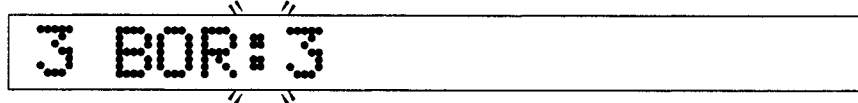

3 BOR: 3

* "3: Boring is done" is selected as an example here.

Press the SET key.



Setting is completed.

12. USING THE F3 AND F4 KEYS

12-4 COD (Cording)

Setting of cording operation

<Procedure>

REMARK: Setting for cording cannot be made during embroidering.

Press the F3 key until number 4 is displayed.

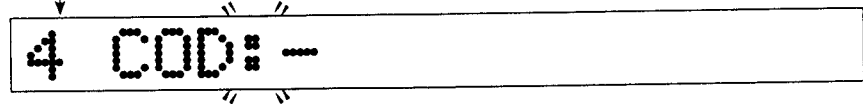

Select cording operation. : No
 : Yes

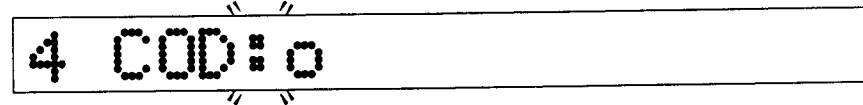

* "Yes" is selected as an example here.

Press the SET key.

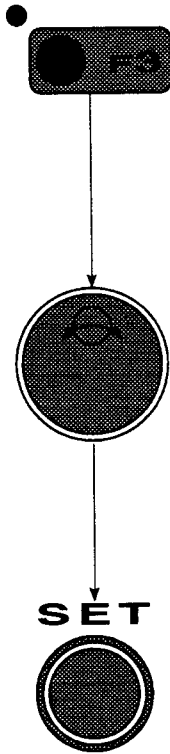

Setting is completed.

12. USING THE F3 AND F4 KEYS

12-5 Network Connection

Setting required when an NW-II (TAJIMA two way network system) is connected.

However, this function is only displayed but not enabled yet. Please do not perform the above operation to avoid malfunction.

<Procedure>



Press the F4 key until number **1** is displayed.



Select network connection. : No
 : Yes



* "Yes" is selected as an example here.

SET

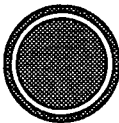

Press the SET key.

Setting is completed.

REMARK: When network connection "Yes" is set, a TFDII or 8RP unit which uses a serial I/F cannot be used.

13. CAUSES OF MACHINE STOPS AND TROUBLESHOOTING

13. CAUSES OF MACHINE STOPS AND TROUBLESHOOTING

13-1 Error Messages

NOTE: If a code number beginning with "3" is displayed, please contact your Tajima distributor.

Code No.	Causes	Corrective Actions
211	A fixed position signal is not detected. (Main shaft Z signal)	Return the main shaft to the fixed position. Check the encoder signal.
225	Stitching outside the embroidery space. (when software frame limit is set)	Correct the design start point. (Move the frame manually so that the design comes in the embroidery space.)
281	Target needle position is not detected in 15 seconds since color change has started.	Return the needle position so that a correct indication is given. Adjust or replace the potentiometer (needle position sensor).
291	Thread breakage is detected.	Check the threads.
2B1	No operation is made for 5 seconds since a read start signal was output by the PTR. No response is received for 5 seconds since the operation was started using a serial I/F. (PTR or serial I/F device is not correctly connected or the tape is torn.)	Check connection of the devices. Repair and correct the tape.
2B2	TAJIMA code complement data error (Same + and - numbers exist in one stitch data.)	Correct the tape.
2B3	Data exists in an end code.	Correct the tape.
2B4	Function code error (A stitch code is not punched at the third character.)	Correct the tape.
2B6	PTR tape signals do not exist. Serial I/F is not ready.	Check the tape setting condition. Set the serial I/F to communications mode.
2B7	The machine was started by using the start switch or frame forward was performed though data was not read in advance.	Perform data input.
2B8	The advance read buffer becomes empty and no output data exists.	During operation: Decrease the rpm. During frame forward: Wait until all design data are read.
2B9	Memory write error	Check or replace the CPU card and/or extension card.
2BA	Memory capacity over	Delete unnecessary designs.

13. CAUSES OF MACHINE STOPS AND TROUBLESHOOTING

Code No.	Causes	Corrective Actions
2BB	Frame back movement exceeded the allowable range.	Do not perform further frame back.
2BC	No design is registered in the memory. An attempt was made to erase from memory the design currently being embroidered.	Register designs in the memory. To erase from memory a design currently being embroidered, either set other design or the same design again by data setting.
2C2	Incorrect option setting	Set correctly.
2CE	Stop due to the pressing of the emergency stop switch	Press the SET key and then press the start switch. (see page 1 – 12).
311	Encoder A signal status did not change for 5 seconds. Motor or motor belt failure.	Check encoder or encoder signal lines. Check the motor or motor belt. Check the main shaft driver for excitation.
312	Encoder Z signal status does not change.	Check the encoder or encoder signal lines.
316	A main shaft driver error signal is detected.	Replace the main shaft driver unit.
322	An X-axis PMD error signal is detected.	Replace the X-axis driver unit.
323	An Y-axis PMD error signal is detected.	Replace the Y-axis driver unit.
382	The needle position signal status during color change does not change for 1 second or more.	Check the color change motor and power supply circuit. Check the potentiometer (needle position sensor).
383	Needle position input signal includes an error. No needle position signal is given when the main shaft is running.	Check the number of needles which was set at the installation of the system. Check the potentiometer (needle position sensor).
3C1	The power switch was turned on with the STOP switch being pushed in.	Turn off the power switch, and then, turn it on. If code "3C1" is still displayed, check the STOP switch.
3D1	Battery backup signal has an error.	Turn on the power supply of the machine and charge the battery. Set parameters and input designs.
3D6	Program or CPU card has an error. The system program has not been correctly installed.	Check the CPU card. Install the system software.
B01	Floppy disk format has an error. An error occurred during read/write operation. Or, use a new initialized floppy disk.	If an uninitialized floppy disk is used, initialize the floppy disk. If this error occurs when reading/writing a specific design, copy other designs to a new floppy disk by using a TFDII, etc. and dispose of the old floppy disk.

13. CAUSES OF MACHINE STOPS AND TROUBLESHOOTING

Code No.	Causes	Corrective Actions
B02	Floppy disk management information has an error.	Copy data of the floppy disk to a new floppy disk by using a TFDII, etc. and dispose of the old floppy disk. Or, use a new initialized floppy disk.
B03	The write protect window of the floppy disk is open.	Close the write protect window or use a new floppy disk. Or, use a new initialized floppy disk.
B04	No floppy disk is inserted.	Insert a floppy disk.
BC1	Selected design is not found on the floppy disk. No design is registered on the floppy disk.	Select other design.
BC2	Set design number already exists on the floppy disk.	Change design number setting.
BC4	Design data was not correctly written from the memory to the floppy disk.	Retry writing.
BC5	Available capacity of the floppy disk is not sufficient.	Use a floppy disk which has enough available capacity.
C01	The FDD unit is faulty.	Replace the FDD unit. Check the FDD connector. If there is no problem with the connection, replace the FDD unit.
1B1	Stop due to a frame stepping code.	These stops are not caused by abnormality or failure. Continue operation by pressing the START key or by conducting the frame back/forward operation, or press any operation key (except the manual frame travel keys).
1B2	Stop due to a stop code.	
1B3	Stop due to end code 1.	
1B4	Stop due to a thread trimming code.	
1C1	Stop by pressing the STOP key during frame stepping.	Either start the machine or conduct frame back/forward. Retry operation.

13. CAUSES OF MACHINE STOPS AND TROUBLESHOOTING

13-2 Troubleshooting

Problem	Cause	Corrective Action
Machine doesn't start	A: Loose or broken belts	Tighten/replace the belt.
	B: Needle position signal, NOT detected.	Adjust the needle position so that needle position signal is properly displayed in the needle position column on the operation panel.
	C: Alarm lamp on the main shaft driver is ON.	Switch the power from OFF to ON.
	D: Poor connection of power supply box connectors.	Securely connect the connectors.
Stop position error	A: Loose or soiled belt	Tighten/clean the belt.
	B: Seizure of driving parts	Adjust/replace the rotary hooks and/or needle bar drive system.
Incorrect color changing	A: Stop position is incorrect.	Adjust the stop (fixed) position.
	B: Position of take-up lever is wrong.	Adjust the position of the take-up lever at the stop position.
	C: Needle position NOT detected.	Adjust the needle position so that needle position is properly indicated in the manual color change section on the operation panel.
Incorrect upper thread tension	A: Poor contact between thread take-up spring and bushing	Clean/adjust thread take-up spring and bushing.
Jump is not performed correctly	A: Incorrect positioning of parts related to needle bar drive system	Adjust the parts to the proper position.
Reading errors	A: Tape is faulty: * Stitch data has + and - versions of same value in it. * Stitch code not at every 3rd character. * Feed holes are irregular. * Feed hole has burr or is clogged. * Tape has no end code.	Correct the tape. Correct the tape. Correct the tape. Correct the tape. Add an end code to the tape.
	B: Reader fails to read.	Clean the reader head.
	C: Worn capstan roller in the reader	Replace.
Design displaced	A: Tape data is faulty.	Correct the tape data.
	B: Incorrect tensioning of frame drive belt	Adjust the tension.
	C: Malfunctioning of frame drive parts	Adjust/replace.
	D: Overall frame weight is excessive.	Lower the r.p.m.
	E: Power supply/driver unit (X, Y-axes) defective	Replace the drive unit. Replace the X-axis/Y-axis drivers.

13. CAUSES OF MACHINE STOPS AND TROUBLESHOOTING

Problem	Cause	Corrective Action
Thread breaks	A: Wrong needle/rotary hook timing or improper needle/rotary hook clearance	Adjust the timing or needle/rotary hook clearance.
	B: Wrong needle bar lower dead point	Adjust the lower dead point.
	C: Scratches on rotary hooks, presser feet, or on thread passage areas	Remove the scratches.
	D: Incorrect upper/lower thread tension	Adjust the tension.
	E: Repeated stitching at the same point	Correct the data.
	F: Incorrect take-up lever timing	Readjust the take-up lever driving cam timing.
A.T.H.	A: Thread is not trimmed.	Adjust the movable knife position. Adjust the timing by the "ATH timing setting".
	B: Thread frayed at the beginning of embroidery	Adjust the thread trimming length by the "ATH (Automatic Thread Trimming)" setting. Set "1" or "2" for the reverse stitching after ATH operation.
	C: Incorrect upper thread tension	Adjust the tension.

14. MAINTENANCE AND OTHER PRECAUTIONS

14-3 Lubrication

⚠ WARNING

During machine lubrication, turn off the power switch.

You may sustain severe injuries due to being entangled by moving machine units.

⚠ CAUTION

When supplying lubricating oil, use only Tajima's genuine SF oil or equivalent (#150 spindle oil: ISO viscosity grade = VG18).

[Lubrication points and lubrication intervals] (See the illustration below and other next page)

Needle bar (a)	Once/week
Needle bar drive shaft for the presser foot (b)	
Arm rail (c)	
Inside the arm (d)	Every 3 - 4 hours of operation
Rotary hook rail (e)	

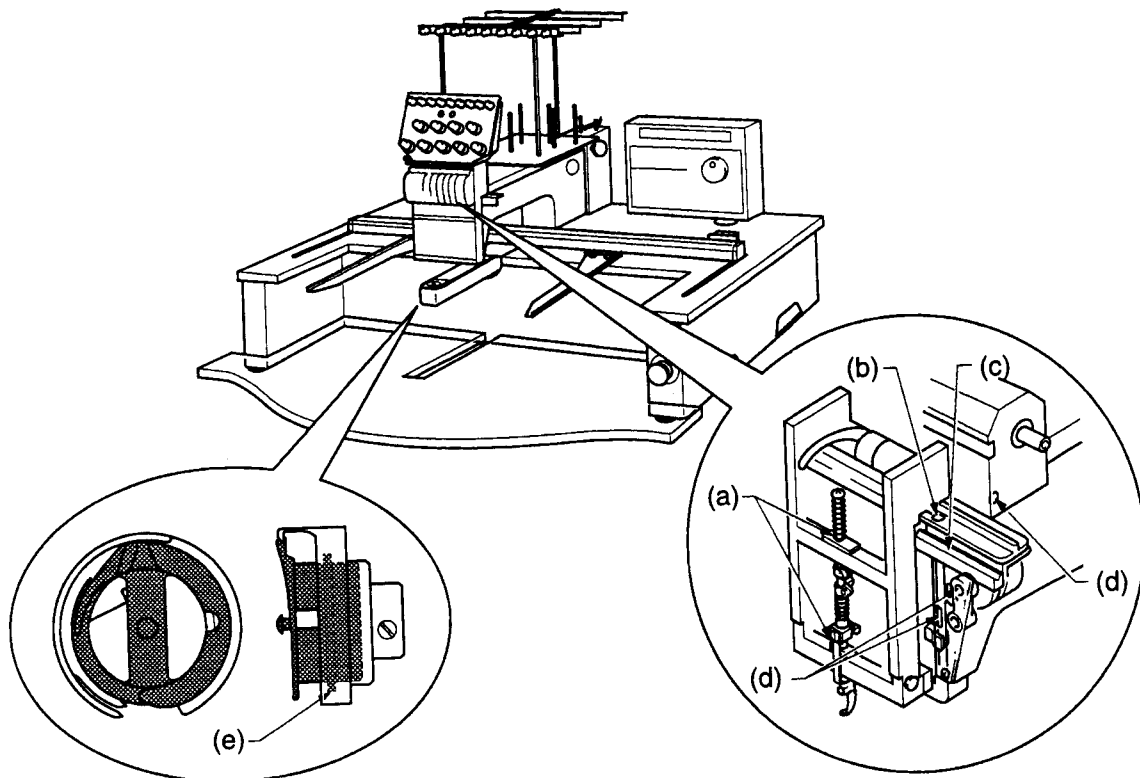

14. MAINTENANCE AND OTHER PRECAUTIONS

Drive shaft for the presser foot reciprocator (a)	Once/week
Needle bar drive shaft (b)	
Inside the arm (c)	
Fitting point between the movable knife and fixed knife in ATH (d)	Once every 2 or 3 weeks

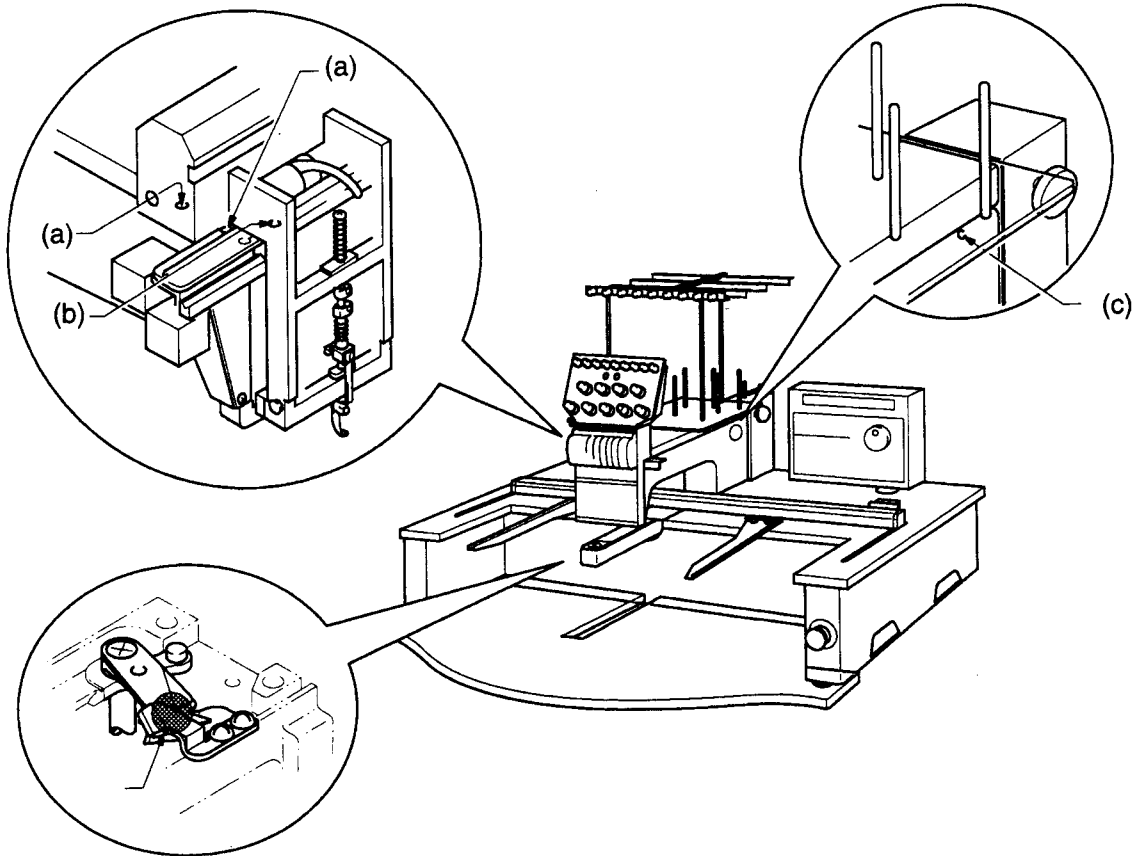

14. MAINTENANCE AND OTHER PRECAUTIONS

14-4 Greasing



During machine greasing, turn off the power switch.

You may sustain severe injuries due to being entangled by moving machine units.



- Please consult your Tajima's distributor for further information about greasing.
- When greasing, use only high quality mineral oil-based lithium grease or equivalent.

[Greasing points and greasing intervals] (See the illustration below)

Take-up lever boss (a)	Once every 2 or 3 months
------------------------	--------------------------

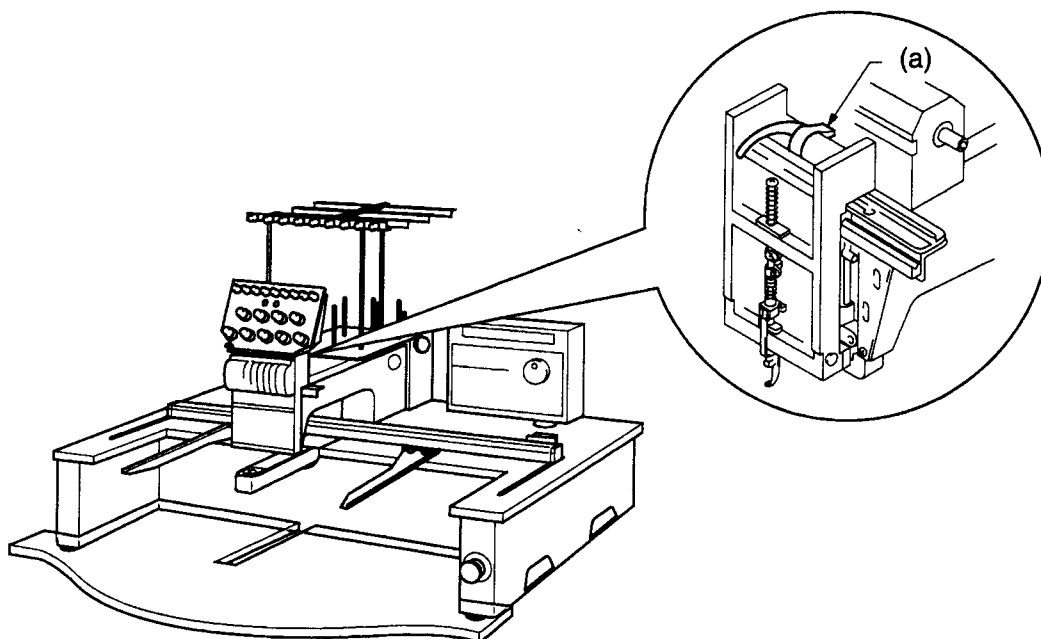

14. MAINTENANCE AND OTHER PRECAUTIONS

14-5 Inspection



WARNING

During machine greasing, turn off the power switch. (Before disconnecting the power, turn off the power switch.)

You may sustain severe injuries due to being entangled by moving machine units.

[Inspection points, contents, and intervals]

Belts in main shaft drive unit	Tension and wear on belt	Once/3 months
X- and Y-axis drive belts	Existence of cracks	
Rotating and sliding sections	Degree of wear	

14-6 Cautions on Repair



WARNING

To prevent accidents resulting in injury or death and physical damage, the following must be observed when performing the repairs of the machine.

- If the machine needs repairs, the repairs must be done only by the service personnel assigned and trained by Tajima or qualified technician.
- Do not change the specification nor modify the parts of the machine without due consultation with Tajima. Such modification may risk the operational safety.
- When restarting the machine after repairs, attach all covers etc. which were removed for the repair operation.



WARNING

During machine cleaning, you may sustain severe injuries due to electric shock or being entangled by moving machine units. Therefore, observe the following items when you clean the machine.

- Before starting cleaning of the machine, be sure to disconnect the power to the machine and wait for 4 minutes. (Before disconnecting the power, turn off the power switch.)
It takes 4 minutes until the machine becomes completely discharged.



CAUTION

For the machine repairs, use TAJIMA GENUINE PARTS for replacement.

TMEX-C901, 1201 Electrical Connection Diagram

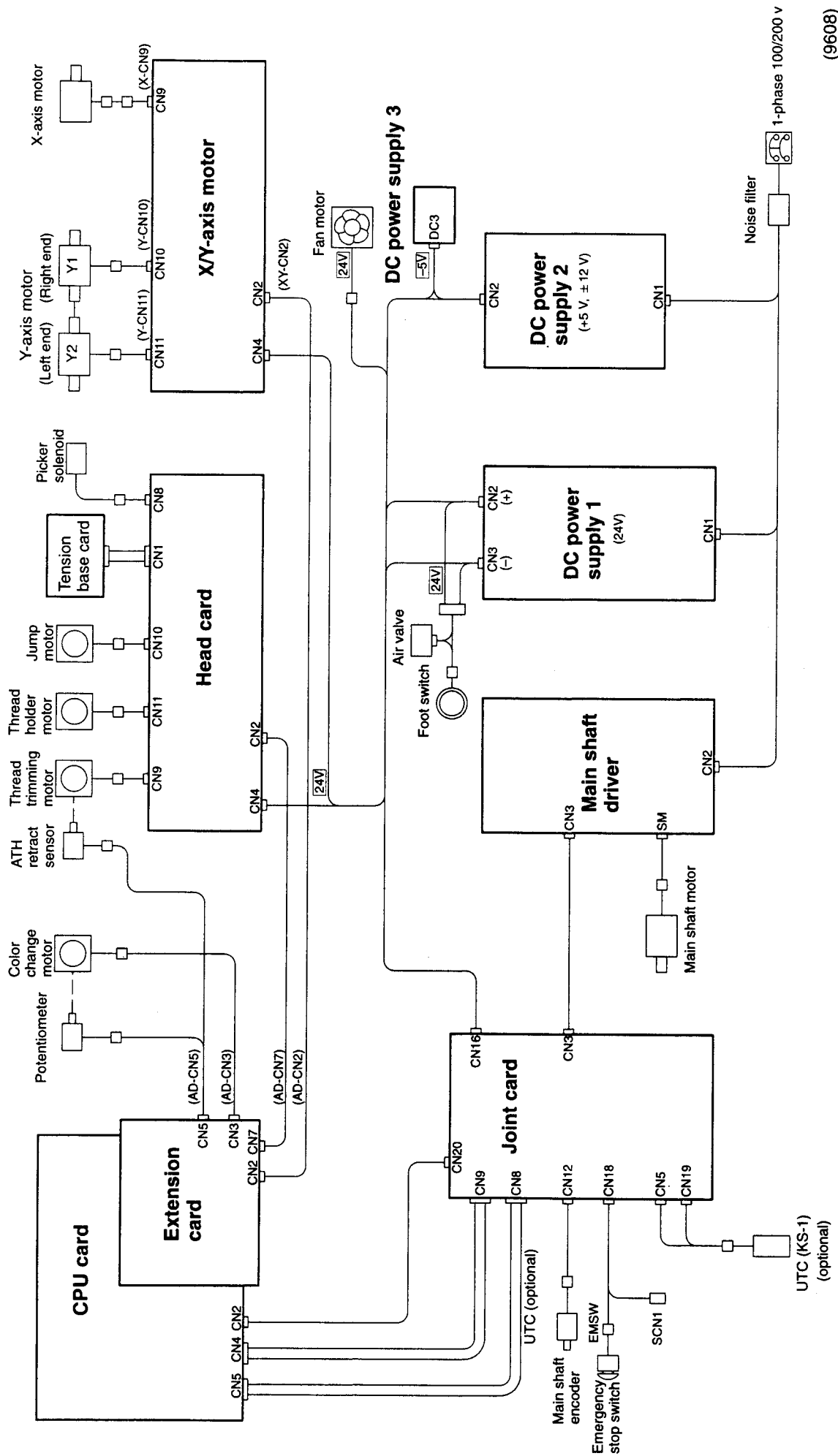

■ **Manufactured by:**
Tokai Industrial Sewing Machine Co., Ltd.

1800 Ushiyama-cho, Kasugai City, Aichi Prefecture, 486 Japan
Telephone: 568-33-1161 Fax: 568-33-1191

■ **Distributed by:**
Tajima Industries Ltd.

3-19-22 Shirakabe, Higashi-ku, Nagoya, 461 Japan
Telephone: 52-932-3444 Fax: 52-932-2457

■ **Authorized Distributor:**

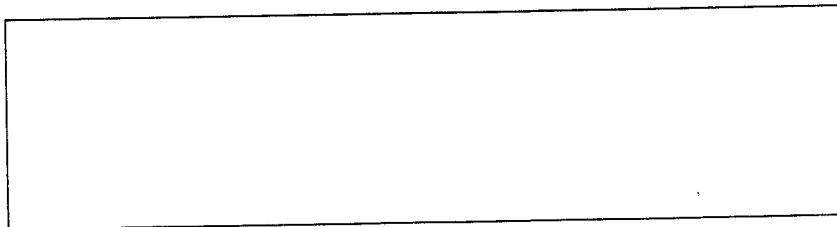



THE TAJIMA GROUP

Tajima Industries Ltd.

19-22, Shirakabe, 3-chome, Higashi-ku, Nagoya, 461, JAPAN
TEL.(052)932-3811 FAX.(052)932-2457

Tokai Industrial Sewing Machine Co.,Ltd.

NO. 1800, Ushiyama-cho, Kasugai, Aichi-pre., 486, JAPAN
TEL.(0568)33-1161 FAX.(0568)33-1191

